



10-70

OPERATING MANUAL

Contents:

- **Catalog Sheet**
- **10-70 Requirements**
- **Before Operating the 10-70**
- **Operating the 10-70**
- **Periodic Maintenance**
- **Service Instructions and Parts List for High Pressure Pump Model 8540-A1**
- **Service Instructions and Parts List for Air Motor Model 324400-5**
- **Service Instructions and Parts List for Pump Tube 331378**
- **Service Instructions & Parts List for Volume Control Valve #6438**
- **Drawing and Parts List for Canister**
- **Additional Parts Listing**

Val-Tex Air Operated Lubrication Equipment



"Quality That Pays For Itself"

These powerful, portable, air operated lubrication guns have a 70:1 ratio air motor to quickly pump bulk lube sealants and Valve Flush. A special follower plate and spring assures positive priming. All units come equipped with a 15,000 PSI gauge, Gauge Guard, dual swivels, control handle, 10 foot, 3/8 inch I.D. high pressure grease hose and whip end hose with giant buttonhead coupler. Fully automated with no manual activation required.

NOTE: When pumping Valve Flush, remove the follower plate.

Delivery: 1/16 ounce per stroke

PSI Rating: 10,000

Self Priming: Spring loaded follower plate

CFM Required: 6

Air Pressure Required: 125 to 185 PSI

Typical Pressure Delivered through a 10 foot hose at 150 PSI:

Lube Sealant - 8,000 PSI

Valve Flush - 8,000 PSI

Gauge: Included

Internal Relief Valve: No

"L'il Greaser" - Model 5-70

The carrying handle makes this compact, portable gun ideal for tight places, overhead lubrication, and easy transporting around the field. The enclosed sealant canister keeps dirt and foreign material out.

For Use With: 5 qt. / 10 lb. can

Dimensions: 25" high X 10" width

Approximate Weight: 50 lbs. / 22.68 kg.



"Easy Lube" - Model 10-70

Caddy type cart with large rubber tired wheels assures easy maneuverability. The enclosed sealant canister keeps dirt and foreign material out.

For Use With: 5 qt. / 10 lb. can

Dimensions: 43" high X 18" wide X 28" long

Approximate Weight: 76 lbs. / 34.47 kg.



"Easy Lube" - Model 40-70

A practical gun for servicing a large number of valves. The reversible pail adapter provides uninterrupted flow. The swing type dolly mounted on rubber tired wheels keeps the container upright at all times. The enclosed sealant canister keeps dirt and foreign material out. Heavy duty latches keep the lid secure.

For Use With: 5 gal. / 40 lb. pail

Dimensions: 37" high X 19" wide X 24" long

Approximate Weight: 78 lbs. / 35.38 kg.



The **Val-Tex 10-70** comes equipped with a modified 8540-A1 High Pressure Pump. The service instructions enclosed provide a general guide as to safety requirements, disassembly, reassembly and parts. Please consult Val-Tex when reordering replacement parts. Standard Alemite parts may not apply.

10-70 Requirements

To obtain 8000 PSI output requires 150 PSI of air at 6 CFM.

Air regulator, moisture separator and oiler (not included) are recommended on the air supply line to prolong the life of the pump.

Before Operating the 10-70

1. Connect lube sealant hose assembly to the motor. Check all threaded connections to ensure the hose assembly is properly tightened.
2. To Pump Lube Sealant:
 - A. Open the can of lube sealant and place it in the bottom of the canister.
 - B. Insert the follower plate into the lube sealant can.
 - C. Clamp the canister lid down by tightening down the knurled nuts on the three thumb screws.
3. To Pump Valve Flush:
 - A. Open the can of Valve Flush and place it in the bottom of the canister.
 - B. Remove the follower plate from the pump tube before use.
 - 1) Remove the snap ring that secures the follower plate to the bottom of the pump tube.
 - 2) Remove the follower plate from the pump tube.
 - C. Insert the pump tube into the Valve Flush can.
 - D. Clamp the canister lid down by tightening down the knurled nuts on the three thumb screws.
4. Connect the air hose to the pump

Operating the 10-70

1. Depressing the control handle (6438) will activate the pump. Continue until material flows from the end of the hose. *
2. Connect to the fitting and begin injecting into the valve.

*Dispose of any expelled material properly.

Periodic Maintenance

1. Refer to service instructions for model 8540-A1.



High-Pressure Pump (Stationary and Portable)

Description

The major components of high-pressure pump assembly models 8540-A1 and 8541-5 consist of a(n):

- air-operated motor
- lubricant pressure controller (pressurtrol)
- double-acting reciprocating pump tube
- cover assembly and follower plate
- control valve, z-swivel, hose, & dolly (Model 8541-5)

The pressurtrol minimizes material pressure drop that occurs when the pump cycles. Refer to SER 319800-1 for details.

Pump Assembly

The high-pressure (70:1 ratio) pump assembly included with each model is designed to deliver a range of greases [up to NLGI # 3] and operates directly from an original 120-pound container.

Models 8540-A1 and 8541-5

Model 8540-A1 is stationary. It contains a cover and follower plate. Model 8541-5 is portable and includes a dolly, control valve, z-swivel, and delivery hose.

Specifications

Air Motor

Piston Diameter x Stroke		Air Inlet	Max. Air Pressure *	
Inches	Centimeters		psi	Bars
3 x 1-5/8	7.6 x 4.1	1/4 " NPTF (f)	200	13.8

* With pressurtrol, [100 psi (6.9 Bars) without pressurtrol]
For information on the air motor, refer to SER 324400-5

Pump Tube

Material Outlet	Max. Material Pressure		Max. Delivery/Minute (Approximate)*		Displacement per Cycle	
	psi	Bars	Ounces	Grams	in ³	cm ³
3/8 " NPTF (f)	7500	517	32	909	0.277	4.54

* For detailed information, refer to Service Guide SER 8540-B

Table 1 Pump Assembly Specifications

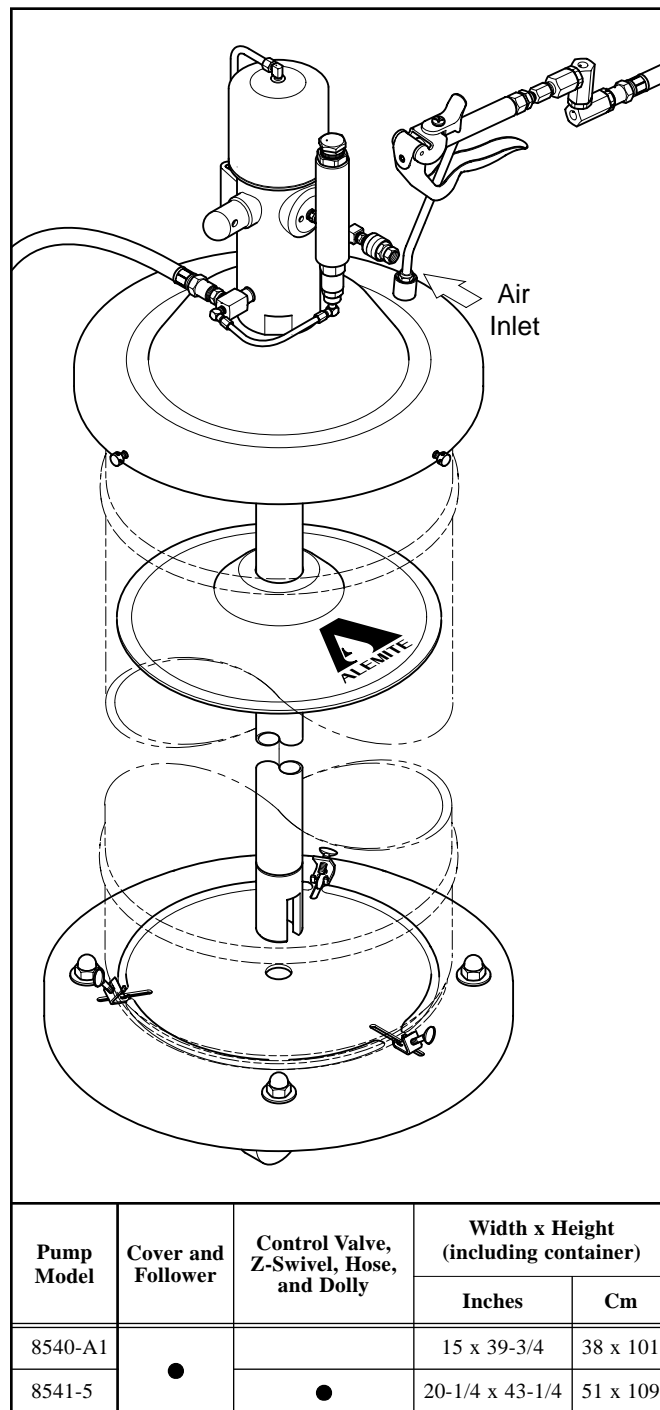

Figure 1 Pump Models 8540-A1 and 8541-5
Model 8541-5 Shown

Pump Model	Cover and Follower	Control Valve, Z-Swivel, Hose, and Dolly	Width x Height (including container)	
			Inches	Cm
8540-A1	●		15 x 39-3/4	38 x 101
8541-5	●	●	20-1/4 x 43-1/4	51 x 109

Alemite Corporation
PO Box 473515, Charlotte, North Carolina 28247-3515
www.alemite.com

Copyright © 1998 by Alemite Corporation

This document contains confidential information that is the property of Alemite Corporation and is not to be copied, used, or disclosed to others without express written permission.

SER 8540-A1
Revision (7-98)

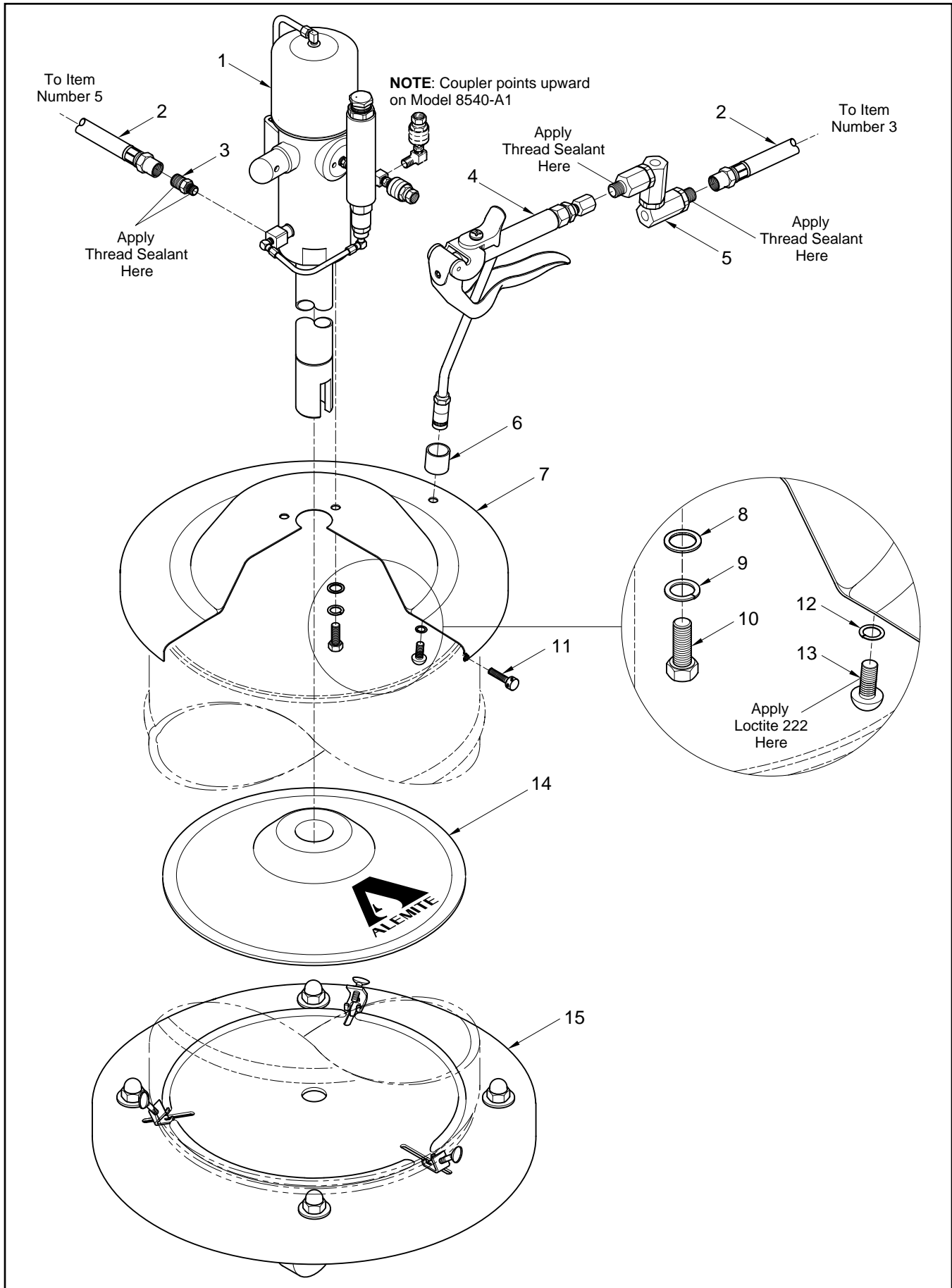

Figure 2 High-Pressure Lubricant Pump (Stationary and Portable) Models 8540-A1 and 8541-5 - Exploded View

Item No.	Part No.	Description	Qty	Notes		Numeric Order Part # (Item #)
1	8540-B	Pump Assembly, High-Pressure	1		See SER 8540-B	6320-3 (4)
2	317875-7	Hose Assembly, Material	1	Model 8541-5		8540-B (1)
3	44734	Adapter, 3/8 " NPTF (m) x 1/2 " -27	1			<i>17804</i> (8)
4	6320-3	Valve Assembly, Control	1		See SER 6320-3	44734 (3)
5	B52752	Z-Swivel Assembly, High-Pressure	1		See Figure 3	48018 (11)
6	315943	Bushing	1			B52752 (5)
7	338371	Cover Assembly	1			<i>77009</i> (12)
8		Washer, 1/4 "	3	Included w/ 338371		<i>77786</i> (10)
9		Washer, Lock, 1/4 "	3			<i>170561</i> (13)
10		Capscrew, 1/4 " -20 x 1/2 "	3			<i>172207-1</i> (9)
11	48018	Screw, Thumb, 1/4 " -28 x 1-1/8 "	3			315953 (6)
12		Washer, Internal Tooth Lock, 1/4 "	1			316315-5 (15)
13		Screw, 1/4 " -20 x 5/16 "	1			317875-7 (2)
14	338802	Plate, Follower	1			320998-B4 (7)
15	316315-5	Dolly Assembly	1	Model 8541-5	See SER 316315-5	338802 (14)
Legend: Part numbers left blank (or in <i>italics</i>) are not available separately						

Assembly

NOTE: Refer to **Figure 2** for component identification on all assembly procedures.

CAUTION

Select a clean environment for all assembly procedures. Prevent contamination from foreign material. Damage to components can occur.

Pump Assembly and Cover

IMPORTANT: Make sure to remove the protective cover from the inlet of Pump Assembly (1).

1. Install Pump Assembly (1) into Cover Assembly (7).
2. Secure the Pump Assembly to the Cover with Washers (8), Lock Washers (9), and Capscrews (10).
 - Tighten the Capscrews securely.

Cover Assembly and Follower Plate

3. Place Follower Plate (14) onto the top of the product.
 - With a wobbling motion, eliminate any air that may be trapped underneath the Follower Plate. Force the product through the hole in the center of the Plate.
4. Guide the pump tube into the Follower Plate and fit the Cover onto the container.
5. Secure the Cover to the container with Thumb Screws (11).

NOTE: On model 8541-5, secure the container to Dolly (15). Refer to SER **316315-5** for details.

Control Valve and Material Hose

NOTE: The following procedures are applicable to pump model 8541-5.

IMPORTANT: Do not apply thread sealant to the first two (2) threads of any connection. Contamination can occur.

WARNING

Do not alter the design of the pump. Never install additional components to the outlet of the pressurtrol.

Personal injury can occur.

6. Screw the 3/8 " NPTF end of Adapter (3) [with thread sealant] into the adapter at the outlet of the air motor.
 - Tighten the Adapter securely.
7. Screw either end of Material Hose (2) into the Adapter [with thread sealant].
 - Tighten securely.
8. Screw the 1/2 " -27 end of Z-Swivel (5) [with thread sealant] into the Material Hose.
 - See **Figure 3**.
 - Tighten securely.
9. Screw the opposite end of the Z-Swivel [with thread sealant] into Control Valve (4).
 - Tighten securely.
10. Test/Prime the Pump assembly.
 - Refer to Service Guide SER **8540-B** for details.

Item No.	Part No.	Description	Notes	Qty
a		Adapter, Swivel, 1/4 " NPTF (m)		1
b		Ring, Support, Male	△	3
c		V-Packing (Rubber)	△	6
d		V-Packing (Leather)	△	3
e		Ring, Support, Female	△	3
f		Body and Stud Assembly		2
g		Adapter, Swivel, 1/2 " -27		1

Legend:
 Part numbers left blank are not available separately
 △ designates a repair kit item

Repair Kit

Part No.	Kit Symbol	Description
398719-1	△	Kit, Repair [Quantity for two (2) Z-Swivels]

Figure 3 High-Pressure Z-Swivel - Exploded View

Changes Since Last Printing

New Format

Air Motor

Description

Overview of Non-Divorced Pumps

The pump tubes that connect to these motors are of a non-divorced design.

Non-divorced pumps contain a packing group that fits directly into the lower portion of the motor. This lower packing group is designed to prevent product from entering the pneumatic portion of the motor. Product is distributed through an outlet in the air motor base. See **Figure 1**.

Pump tube separation requires that the pump tube (with attached components) be unthreaded from the base of the air motor.

Models 324400-2, 324400-4, and 324400-5

The difference between the models in the 324400 series air motors is illustrated in **Figure 1**.

The obsolete lower packing group in air motor model 324400-2 can be updated with the molded lower packing group kit that is current in model 324400-4.

These two models contain an obsolete body. Each of these models can be updated to the current model (324400-5) with the use of a body replacement kit.

NOTE: With this kit it is necessary to purchase the stepped toggle cap with the o-ring seal along with the current molded lower packing group.

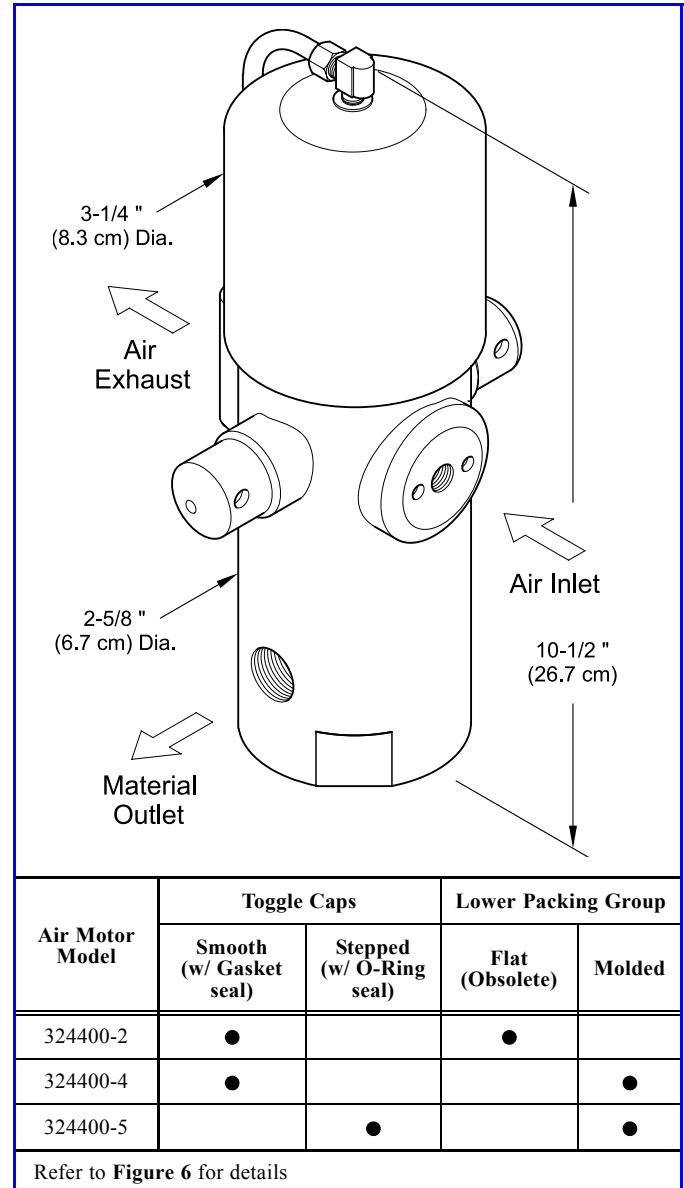

Figure 1 Air Motor Model 324400 Series
Model 324400-5 Shown

Specifications

Piston Diameter x Stroke		Air Inlet	Material Outlet	Maximum Air Pressure	
Inches	Centimeters			psi	Bars
3 x 1-5/8	7.6 x 4.1	1/4 " NPSI (f)	3/8 " NPTF (f)	200	13.8

Table 1 Air Motor Model 324400 Series Specifications

Alemite Corporation
PO Box 473515, Charlotte, North Carolina 28247-3515
www.alemite.com

Copyright © 2002 by Alemite Corporation

This document contains confidential information that is the property of Alemite Corporation and is not to be copied, used, or disclosed to others without express written permission.

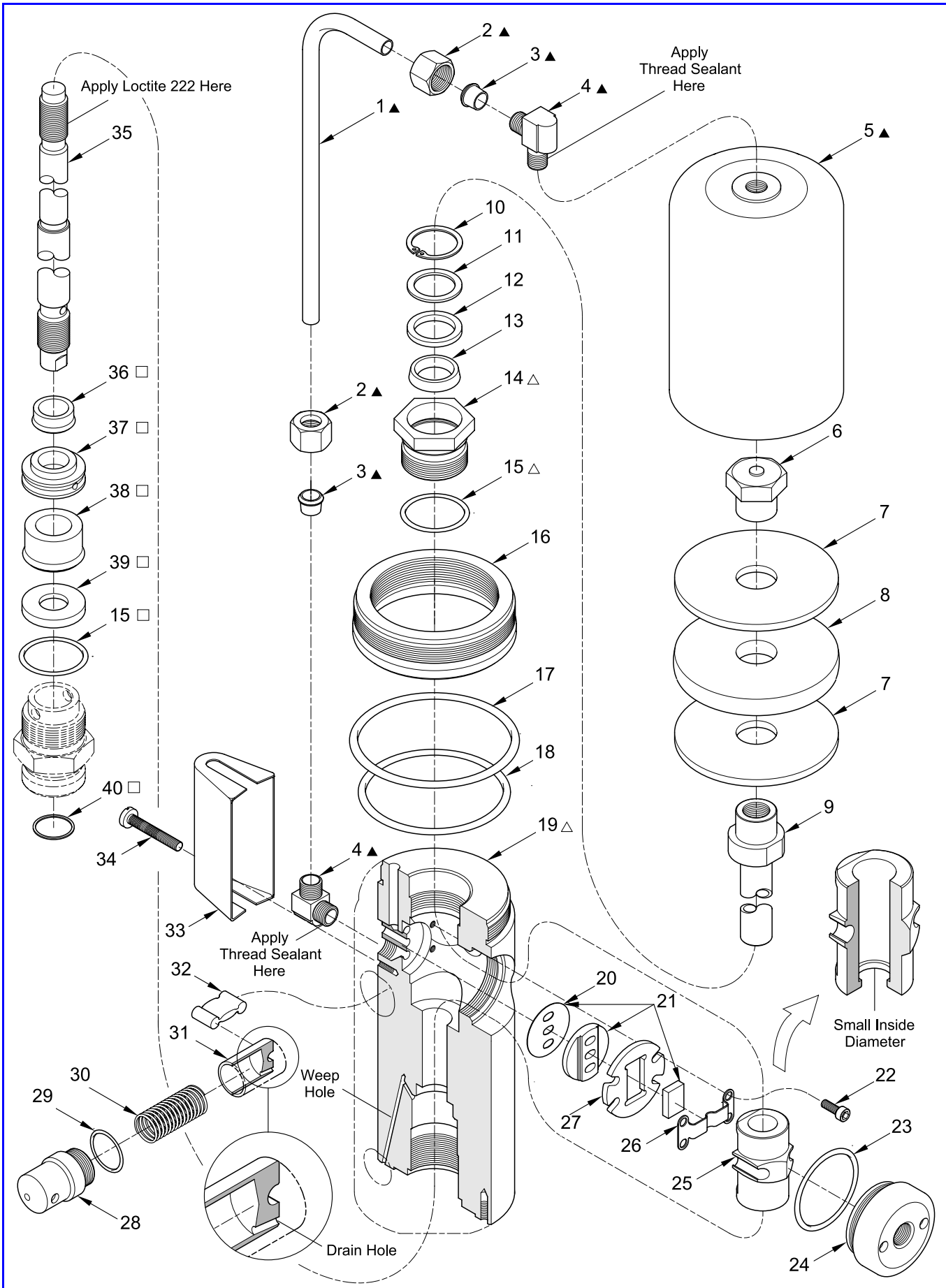

Figure 2 Air Motor Model 324400-5 (with High-Pressure Pump Tube Adapter) - Exploded View

Item No.	Part No.	Description	Qty	Notes	Numeric Order Part # (Item #)
1	331244	Tube, 5/16 " OD	1	▲	(2)
	328306-52	Fitting, Compression	2		(3)
2		Nut, Compression, 1/2 " -24	2	▲	(4)
3		Sleeve, Compression, 5/16 "	2	▲	51017 (40)
4		Elbow, 1/2 " -24 x 1/8 " NPTF (m)	2	▲	131618 (7)
5	331843-4	Cylinder	1	▲	170290 (34)
6	321086	Nut, Piston	1		171000-14 (29)
7	131618	Washer	2		171003-11 (17)
8	321082	Packing (Rubber)	1		171006-15 (10)
9	320749	Spacer	1		171009-29 (23)
10	171006-15	Ring, Retaining	1		171009-41 (18)
11	320748	Washer (Brass)	1		171013-12 (15)
12	314671	Washer (Leather)	1		171636 (22)
13	314670	V-Packing	1		172190-3 (36)
14	320745	Nut, Packing	1	△	172190-11 (38)
15	171013-12	O-Ring, 1-1/8 " ID x 1-1/4 " OD	2	△ □	Qty of 1 in each kit 314670 (13)
16	321087	Adapter	1		314671 (12)
17	171003-11	O-Ring, 2-7/8 " ID x 3-1/8 " OD	1		317524 (30)
18	171009-41	O-Ring, 2-5/16 " ID x 2-1/2 " OD	1		317529 (33)
19		Body	1	△	320727 (24)
20		Gasket	1		320731 (20)
21	398439	Valve and Seat Assembly (w/ Gasket)	1		320736 (25)
22	171636	Screw, 10- 32 x 3/8 "	4		320737 (32)
23	171009-29	O-Ring, 1-9/16 " ID x 1-3/4 " OD	1		320745 (14)
24	320727	Inlet, Body	1		320746 (35)
25	320736	Shuttle	1		320748 (11)
26	330842	Spring, Valve Retaining	1		320749 (9)
27	330843	Retainer, Valve	1		321082 (8)
28	337471	Cap, Toggle (Stepped)	2		321086 (6)
29	171000-14	O-Ring, 3/4 " ID x 15/16 " OD	2		321087 (16)
30	317524	Spring	2		321457 (31)
31	321457	Plunger	2		328306-52
32	320737	Toggle	2		330842 (26)
33	317529	Muffler	1		330843 (27)
34	170290	Screw, 8 -32 x 1 "	1		331244 (1)
35	320746	Rod, Piston	1		331843-4 (5)
36		Seal, 0.437 " ID x 0.687 " OD	1	□	337386 (37)
37		Ring, Lantern	1	□	337387 (19)
38		Seal, 0.437 " ID x 0.937 " OD	1	□	337394 (39)
39		Washer	1	□	337471 (28)
40	51017	Gasket, 0.815 " ID (Aluminum)	1	□	High-Pressure Pump 398439 (21)

Legend:
Part numbers left blank (or in *italics*) are not available separately
▲□△ designates a repair kit item

Repair Kits

Part No.	Kit Symbol	Description	Notes
393496-1		Kit, Major Repair	See Figure 3
393495	□	Kit, Lower Packing Group (Includes protective sleeve)	
393124	▲	Kit, Cylinder Repair	
393533	△	Kit, Body Repair	

NOTE: Additional repair kits for air motor model 324400 series are illustrated on the following page.

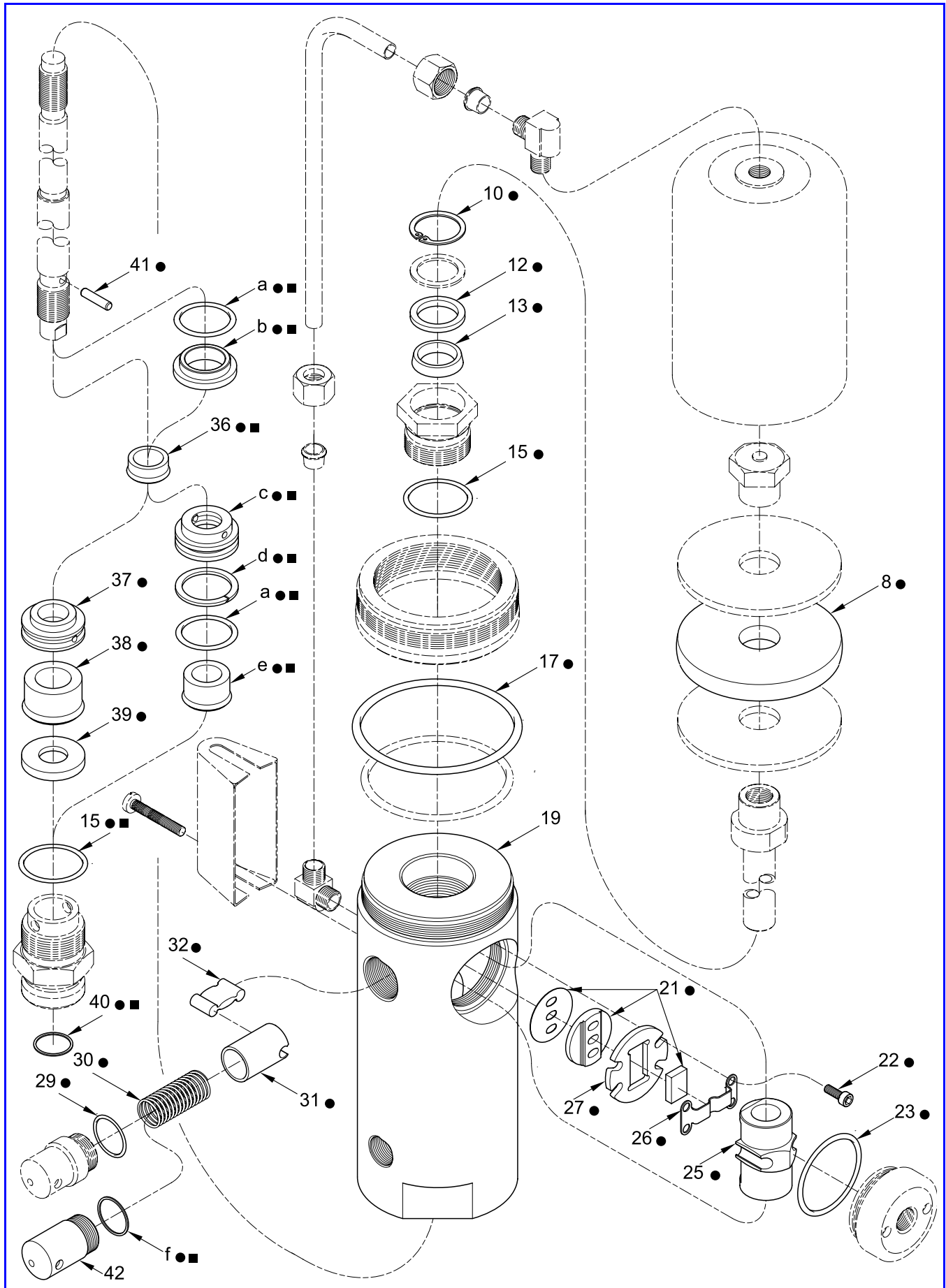

Figure 3 Additional Kits for Air Motor Model 324400 Series- Exploded View

Item No.	Part No.	Description	Qty	Notes	Numeric Order Part # (Item #)
8	321082	Packing (Rubber)	1	●	51017 (40)
10	171006-15	Ring, Retaining	1	●	171000-14 (29)
12	314671	Washer (Leather)	1	●	171006-15 (10)
13	314670	V-Packing	1	●	171009-19 (a)
15	171013-12	O-Ring, 1-1/8 " ID x 1-1/4 " OD	2	●■	Qty of 1 in ■ kit 171009-29 (23)
17	171003-11	O-Ring, 2-7/8 " ID x 3-1/8 " OD	1	●	171009-41 (18)
19		Body (Obsolete)	1		Model 324400-2 & -4 171013-12 (15)
21	398439	Valve and Seat Assembly (w/ Gasket)	1	●	171636 (22)
22	171636	Screw, 10- 32 x 3/8 "	4	●	172190-2 (e)
23	171009-29	O-Ring, 1-9/16 " ID x 1-3/4 " OD	1	●	172190-3 (36)
25	320736	Shuttle	1	●	172190-11 (38)
26	330842	Spring, Valve Retaining	1	●	314670 (13)
27	330843	Retainer, Valve	1	●	314671 (12)
29	171000-14	O-Ring, 3/4 " ID x 15/16 " OD	2	●	317524 (30)
30	317524	Spring	2	●	320724 (42)
31	321457	Plunger	2	●	320736 (25)
32	320737	Toggle	2	●	320737 (32)
36		Seal, 0.437 " ID x 0.687 " OD	1	●■	320971 (41)
37		Ring, Lantern	1	●	321082 (8)
38		Seal, 0.437 " ID x 0.937 " OD	1	●	321457 (31)
39		Washer	1	●	321458 (f)
40	51017	Gasket, 0.815 " ID (Aluminum)	1	●■	327329 (19)
41	320971	Pin	1	●	330842 (26)
42	320724	Cap, Toggle (Smooth)	1		Model 324400-2 & -4 330843 (27)
Kit Items Applicable to Models 324400-2 and 324400-4					337093 (b)
a		O-Ring, 1 " ID x 1-3/16 " OD	2	●■	337096 (c)
b		Ring	1	●■	337097 (d)
c		Adapter	1	●■	337386 (37)
d		Ring, Split (Nylon)	1	●■	337394 (39)
e		Seal, 0.430 " ID x 0.804 " OD	1	●■	398439 (21)
f	321458	Gasket, 0.885 " ID (Aluminum)	2	●■	

Legend:
Part numbers left blank (or in *italics*) are not available separately
● ■ designates a repair kit item

Repair Kits

Part No.	Kit Symbol	Description	Notes
393496-1	●	Kit, Major Repair (Includes protective sleeve)	
393487	■	Kit, Lower Packing Group (Includes protective sleeve)	Models 324400-2 & -4
393530-2		Kit, Seal [Includes five (5) of item e]	
393530-3		Kit, Seal [Includes five (5) of item 36]	
393530-11		Kit, Seal [Includes five (5) of item 38]	

Service Hints

Refer to the Overhaul Procedures for Details

Soak Leather Washer in Clean Oil for Eight Hours Prior to Installation
V-Packing Requires Lubrication

Tighten Screws Alternately and Evenly from 25 to 30 Inch-Pounds (2.8 - 3.4 Nm)
Screw Heads may Break

Inspect the Surfaces Contacted by the Shuttle for Damage
Lips of Shuttle may Break

Inspect Piston Rod for Straightness
Air Leakage can Occur

Install Seals after Installation of Piston Rod
Damage to Seals may Occur

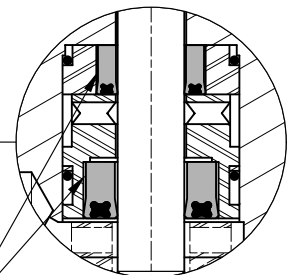

Model 324400-4

Air Motor Shown with Medium-Pressure Adapter

IMPORTANT: Prior to performing any maintenance procedure, the following safety precautions must be observed. Personal injury may occur.



WARNING

Do not use halogenated hydrocarbon solvents such as methylene chloride or 1,1,1-trichloroethane in this motor. An explosion can result within an enclosed device capable of containing pressure when aluminum and/or zinc-plated parts come in contact with halogenated hydrocarbon solvents.

Release all pressure within the system prior to performing any overhaul procedure.

- **Disconnect the air supply line from the motor.**
- **Into an appropriate container, operate the control valve to discharge remaining pressure within the system.**

Read each step of the instructions carefully. Make sure a proper understanding is achieved before proceeding.

Overhaul

NOTE: Refer to **Figures 2 and 3** for component identification on all overhaul procedures.

Disassembly

Separate Pump from Air Motor

1. Clamp the air motor assembly horizontally in a soft-jaw vise.

CAUTION

Support the pump tube assembly during removal. Damage to components can occur.

2. Unscrew the pump tube [with attached components] from the air motor.
3. Pull on the pump tube to expose the coupling.
4. Remove upper Pin (41) that secures the air motor Piston Rod to the coupling.
5. Unscrew the coupling from the air motor Piston Rod.
 - Rotate the entire pump tube assembly.

6. Remove the adapter from Body (19).
7. Remove O-Ring (15) from the adapter.
8. Remove Gasket (40) from the high-pressure adapter.

Air Motor

Toggle Cap Assembly

1. Unscrew Toggle Caps (28 or 42) from Body (19).
 - Use special tool 398500-2. See **Figure 4**.
2. Remove Springs (30) from each Toggle Cap.
3. Remove O-Rings (29) from each Toggle Cap.

NOTE: Cap (42) seals with Gasket (f).

Cylinder and Upper Packings

4. Remove Screw (34) that secures Muffler (33) to the Body.
 - Remove the Muffler.
5. Loosen each Compression Nut (2) from Elbows (4).
6. Remove Tube (1) [with Compression Sleeves (3) and Nuts] from the Elbows.

NOTE: The Tube, Compression Sleeve, and Nut assembly can be reused if no marring or distortion is visible.

7. Unscrew Cylinder (5) from Adapter (16).
8. Remove O-Ring (17) from the Adapter.
9. Grip the flats of Spacer (9) and unscrew Piston Nut (6) from Piston Rod (35).
10. Remove Washer (7), Packing (8) and additional Washer (7) from the Spacer.

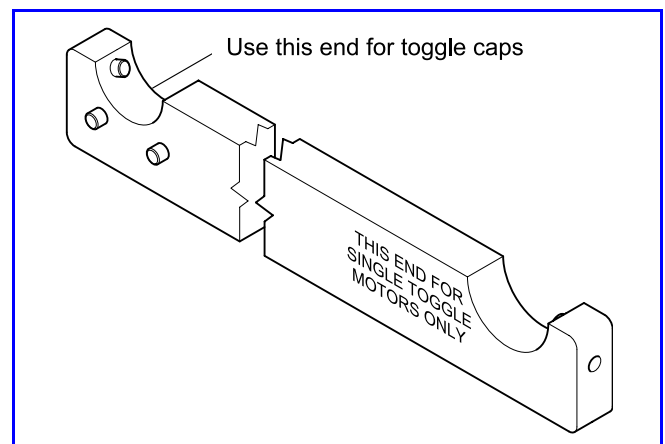

Figure 4 Spanner Wrench 398500-2 (Special Tool)

11. Grip the flats of the Piston Rod and unscrew the Spacer.
12. Remove the Piston Rod from the Body.
13. Remove Retaining Ring (10) from Packing Nut (14).
 - Use internal circlip pliers.
14. Remove Brass Washer (11), Leather Washer (12), and V-Packing (13) from the Packing Nut.

Body Inlet

15. Unscrew Body Inlet (24) from the Body.
 - Use the special tool.
16. Remove O-Ring (23) from the Inlet Body.
17. Maneuver Shuttle (25) to remove Plungers (31) from Toggles (32).
18. Remove the Toggles from the Shuttle.
19. Remove the Shuttle from the Body.

Valve and Seat Assembly

20. Remove Screws (22) that secure Valve Retaining Spring (26) to the Body.
 - Remove the Valve Retaining Spring.
21. Remove the Valve from the Seat.
22. Remove Valve Retainer (27), the Valve Seat, and Gasket (20) from the Body.

Lower Packing

- NOTE:** Model 324400-2 contains a packing group that is obsolete. This model can use the packing group in:
- model 324400-4
 - model 324400-5 with a new Body. See **Figure 6**.

Model Dependent Step

23. Remove Washer (39), Seal (38), Lantern Ring (37), and Seal (36) from the Body [*model 324400-5*].
- Remove Adapter (c) [with attached components] and Ring (b) [with attached components] from the Body.
- Remove Seal (e), O-Ring (a), and Split Ring (d) from the Adapter.
 - Remove Seal (36) from the Ring.
 - Remove additional O-Ring (a) from the Body [*model 324400-4*].

Remove and discard the stacked group from the Body [*model 324400-2*].

Optional Procedures

24. Unscrew Elbows (4) from the Cylinder and the Body as required.

25. Unscrew Packing Nut (14) from the Body as required.
 - Remove O-Ring (15).
26. Unscrew Adapter (16) from the Body as required.
 - Remove O-Ring (18).

NOTE: The Packing Nut and Adapter are staked to the Body in three places.

Clean and Inspect

NOTE: Use the appropriate repair kit for replacement parts. Make sure all the components are included in the kit before discarding used parts.

1. Clean all metal parts in a cleaning solvent. The solvent should be environmentally safe.
2. Inspect all parts for wear and/or damage.
 - Replace as necessary.
3. Inspect the large diameter of Piston Rod (35) and the inside diameter of Cylinder (5) closely for score marks.
 - Replace as necessary.
4. Inspect the Piston Rod for straightness.
 - Roll the Piston Rod on a flat surface by hand.
5. Make sure the shoulder of the Piston Rod is square.
6. Closely inspect the mating surfaces of the Valve Seat and the Valve Slide (21). Ensure a smooth and clean contact is obtained.
 - Replace as necessary.
7. Inspect the bottom of interior bore in Body (19) for deformity due to excessive hammering.
 - Replace the Body with a kit as required.

Assembly

NOTE: Prior to assembly, certain components require lubrication. Refer to **Table 2** for details.

Air Motor

NOTE: Refer to **Figure 6** for a section view of the Air Motor Assembly.

1. Install O-Ring (18) onto Body (19) as required.
2. Screw and seat Adapter (16) onto the Body.
 - Stake the Adapter to the Body in three places. See **Figure 5**.

Upper Packing

3. Install O-Ring (15) onto Packing Nut (14) as required.

4. Screw and seat the Packing Nut into Body (19).
 - Stake the Packing Nut to the Body in three places. See **Figure 5**.
5. Install and seat V-Packing (13) [lip side first], Leather Washer (12), and Brass Washer (11) into the Packing Nut.
6. Install Retaining Ring (10) into the Packing Nut.
 - Use internal circlip pliers.

Valve, Seat, and Shuttle Assembly

7. Install and seat Gasket (20) and Valve Seat (21) into the Body.
 - Make sure the holes are in alignment.
8. Install and seat Valve Retainer (27) [flat side first] onto the Valve Seat.
9. Install Valve (21) [concave side first] into the opening of the Valve Retainer and onto the Valve Seat.
10. Position Valve Retaining Spring (26) onto the Slide Valve and Valve Retainer.

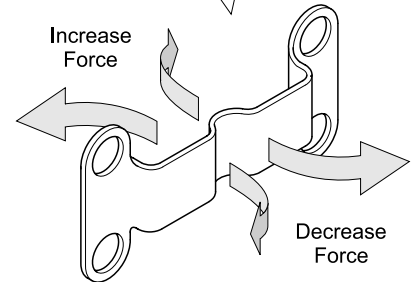
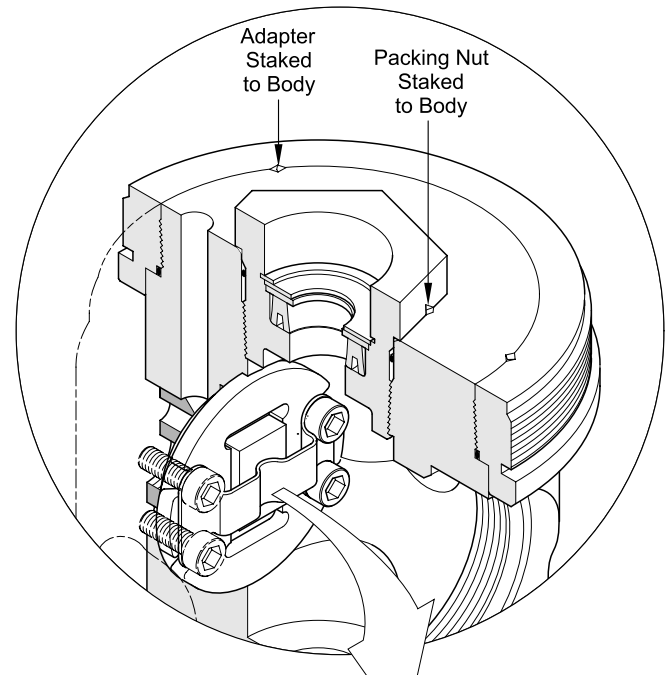

Figure 5 Valve Retaining Spring Adjustment

CAUTION

Do not overtighten Screws (22). Damage to the Valve Retaining Spring can occur.

11. Install Screws (22) that secure the Valve Retaining Spring to the Body.
 - Torque the Screws alternately in a crisscross pattern to 27 inch-pounds (3 Nm) .

Item No.	Description	Item No.	Description
Clean Oil			
12	Washer (Leather) [Soak 8 hours at room temperature]	23	O-Ring, 1-9/16 " ID x 1-3/4 " OD
13	V-Packing	29	O-Ring, 3/4 " ID x 15/16 " OD
15	O-Ring, 1-1/8 " ID x 1-1/4 " OD	36	Seal, 0.437 " ID x 0.687 " OD
17	O-Ring, 2-7/8 " ID x 3-1/8 " OD	38	Seal, 0.437 " ID x 0.937 " OD
18	O-Ring, 2-5/16 " ID x 2-1/2 " OD	e	Seal, 0.430 " ID x 0.804 " OD
a	O-Ring, 1 " ID x 1-3/16 " OD		
Viscous H Lubricant			
5	Cylinder - Inside Bore	25	Shuttle - Inside Diameter and Toggle Sockets
8	Packing - Outside Diameter	28 (42)	Toggle Cap - Inside Bore
19	Body - 1/4 oz. (7 gms) in Cavity	30	Spring - Coated
21	Valve Slide - Surface in Contact with Spring Retainer	31	Plunger - Outside Diameter and Toggle Socket
NOTE: Part number 398030 is a 2 ounce (57 gm) tube of Viscous H Lubricant			

Table 2 Lubricated Components

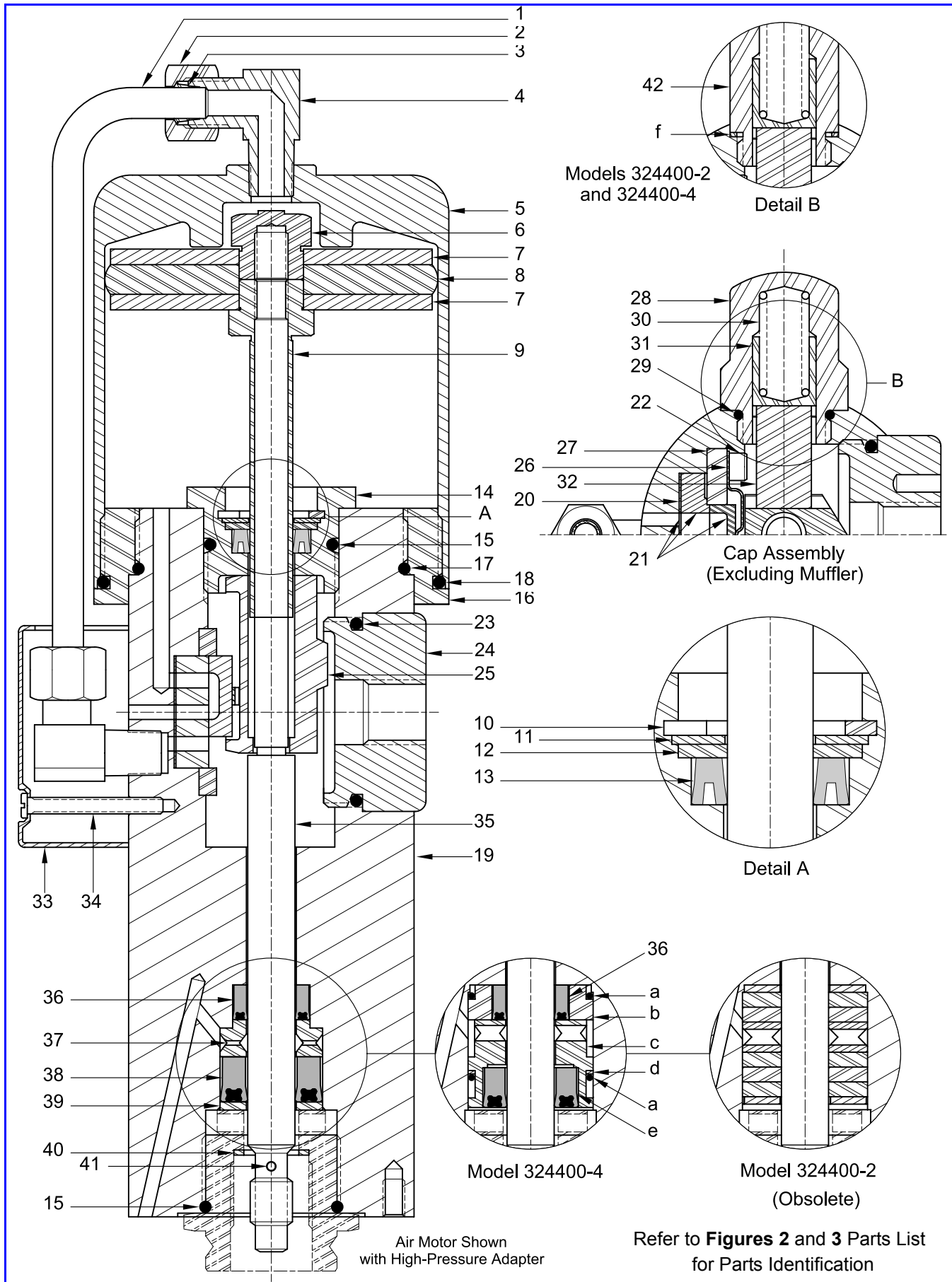

Figure 6 Air Motor Model 324400 Series - Section View

12. Measure the amount of force required to move the Valve on the Valve Seat.

NOTE: The Valve should begin to move with approximately 8 ounces (227 gms) of force. If the force is too great or too slight, remove the Valve Retaining Spring and carefully bend by hand. See **Figure 5**.

*IMPORTANT: Make sure the smaller inside diameter on Shuttle (23) points downward. See **Figure 2**.*

13. Install Shuttle (25) [flat side first and small inside diameter downward] into the Body and onto the Valve.
14. Install each Toggle (32) onto the Shuttle .

Piston Rod Assembly

15. Install Piston Rod (35) [small diameter first] into the bottom of the Body and through the Shuttle.
16. Install Spacer (9) [stem end first] onto the top of the Piston Rod [with Loctite 222] and into the V-Packing.
- Use care not to damage the V-Packing.
17. Screw the Spacer onto the Piston Rod until it seats.
- Grip the flats at the bottom of the Piston Rod.
18. Install Washer (7), Packing (8) and additional Washer (7) onto the Spacer and Piston Rod.
19. Screw Piston Nut (6) onto the Piston Rod and into the Washer and Packing.
- Grip the flats of the Piston Rod and tighten the Piston Nut to 10 foot-pounds (13.5 Nm).
20. Screw Spacer (9) [counterclockwise] against the Piston Nut.
- Tighten to 20 foot-pounds (27 Nm).

Toggle Caps and Body Inlet

*IMPORTANT: Make sure the drain hole on Plunger (31) points downward. See **Figure 2**.*

21. Install Plunger (31) [drain hole downward] onto each Toggle.
22. Install Spring (30) into each Toggle Cap (28 or 42).

Model Dependent Step

23. Install O-Ring (29) onto each Toggle Cap (28) [model 324400-5].

Install Gaskets (f) onto Toggle Caps (42) [models 324400-2 and 324400-4].

CAUTION

Make sure each Toggle is centered in the Shuttle and the Plunger before Toggle Cap installation. Damage to the Toggle can occur.

24. Screw the Toggle Caps into the Body.
- Make sure the Spring aligns properly.
 - Tighten each Toggle Cap securely with the use of special tool 398500-2. See **Figure 4**.
25. Install O-Ring (23) onto Body Inlet (24).
26. Screw the Body Inlet into the Body.
- Tighten the Body Inlet securely with the use of the special tool.

Cylinder Assembly

27. Install O-Ring (17) onto Adapter (16).

CAUTION

Install Cylinder (5) squarely over the Packing assembly. Thread damage can occur.

28. Carefully install Cylinder (5) over the Packing assembly.
- Screw the Cylinder securely onto the Adapter.
29. Apply thread sealant to Elbows (4). See **Figure 2**.

CAUTION

Do not overtighten the Elbow into the Body. Too much force can damage the surface used for seating Valve Assembly (21).

30. Screw the Elbows into the Body and Cylinder.
- Make sure to orient the Elbows properly.
31. Slide Compression Nut (2) [small diameter first] and Ferrule (3) [large diameter first] onto each end of Tube (1).

NOTE: The old Tube, Compression Sleeve, and Nut assembly can be reused if no marring or distortion is visible.

32. Position the Tube Assembly onto each Elbow.
33. Tighten each Compression Nut securely.
34. Secure Muffler (33) to the Body with Screw (34).
- Tighten the Screw securely.

Lower Packing

NOTE: Procedures 35 - 39 are applicable to model 324400-5.

35. Install and seat Seal (36) [heel end first] onto the Piston Rod and into the Body.
- Use the protective sleeve included in the kit. See **Figure 7**.

36. Remove the protective sleeve from the Piston Rod.

37. Install and seat Lantern Ring (37) [small diameter first] into the Body.

38. Install and seat Seal (38) [heel end first] onto the Piston Rod and into the Body.
- Use the protective sleeve included in the kit.

39. Install Washer (39) into the Body.

NOTE: Procedures 40 - 47 are applicable to models 324400-2 and 324400-4.

40. Install and seat O-Ring (a) into the Body.
- Use care not to damage the O-Ring when passing the weep hole.

41. Install and seat Ring (b) [small diameter first] into the Body.

42. Install and seat Seal (36) [heel end first] onto the Piston Rod and into the Ring.
- Use the protective sleeve included in the kit. See **Figure 7**.

43. Remove the protective sleeve from the Piston Rod.

44. Position Adapter (c) large diameter upward.

45. Install Split Ring (d) and additional O-Ring (a) into the groove of the Adapter.

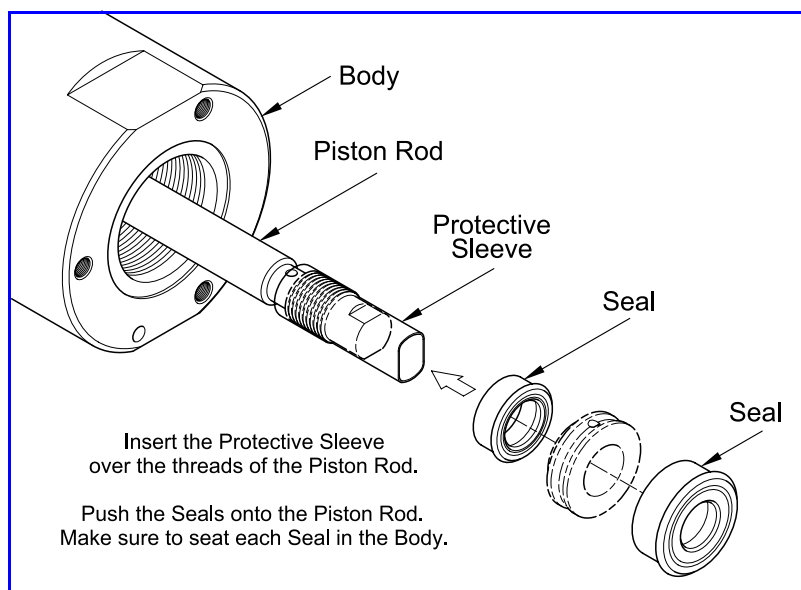

Figure 7 Use of Kit Sleeve to Install Seals onto the Piston Rod
Model 324400-5 Shown

46. Install and seat the Adapter assembly [small diameter first] into the Body.
47. Install and seat Seal (e) [heel end first] onto the Piston Rod and into the Adapter.
- Use the protective sleeve included in the kit.

Connect Pump to Air Motor

48. Clamp the air motor assembly horizontally in a soft-jaw vise.

49. Install O-Ring (15) onto the pump tube's adapter.

50. Screw the adapter into the Body of the air motor.
- Tighten the adapter securely.

51. Install and seat Gasket (40) into the high-pressure adapter (high-pressure pump only).

52. Pull on the pump tube to expose the coupling as necessary.

CAUTION

Support the Pump Tube assembly during installation. Damage to components can occur.

53. Screw the coupling onto the air motor Piston Rod.
- Rotate the entire pump tube assembly.
54. Install Pin (41) that secures the air motor Piston Rod to the coupling.
55. Screw the pump tube securely to the adapter.

Pump Operation



WARNING

Do not exceed the lowest pressure rating of any component in the system.

Never point a control valve at any portion of your body or another person. Lubricant discharged at high velocity can penetrate the skin and cause severe injury. Should any fluid appear to puncture the skin, get medical care immediately.

Ensure all components are in operable condition. Replace any suspect parts prior to operation. Personal injury can occur.

1. Make sure air pressure at the regulator reads zero.
2. Slowly supply air pressure [not to exceed 25 psi (1.7 Bars)] to the pump's motor.
 - The pump assembly should cycle.

If the pump assembly does not cycle, refer to the **Troubleshooting Chart** for details.

With air pressure at zero:

3. Connect a product hose to the pump's material outlet.
 - Direct the hose into an appropriate container.
4. Place the pump in the product to be dispensed.
5. Slowly supply air pressure to the pump's motor.
6. Allow the pump to cycle slowly until the system and product is free of air.

If the pump assembly does not prime, refer to the **Troubleshooting Chart** for details.



WARNING

Should leakage occur anywhere within the system, disconnect air to the motor. Personal injury can occur.

With air pressure at zero:

7. Attach a control valve to the outlet hose of the pump.
8. Slowly supply 35 psi (2.4 Bars) air pressure to the pump's motor.
9. Operate the control valve into a container.
10. Allow the pump to cycle until the system and product is once again free of air.
11. Shut off the control valve.
12. Set the air pressure to 100 psi (6.9 Bar).
13. Visually inspect the pump for external leaks.
 - The pump should not cycle.

If the pump does not stall, refer to the **Troubleshooting Chart** in the **Pump Service Guide** for details.

14. Check the motor for air leakage.

If the motor leaks, refer to the **Troubleshooting Chart** for details.

Installation

Additional items that should be incorporated into the air piping system are listed in **Table 3**.

Part Number	Description
338860	Moisture Separator/Regulator & Gauge Combination
5604-2	Moisture Separator
SM7604-B	Regulator and Gauge
5904-2	Lubricator *

Table 3 Air Line Components

* Although the air motor is lubricated at the factory, the life of the motor can be extended with the use of a lubricator.

Troubleshooting Chart

Indications	Possible Problems	Solution
Air Motor and/or Pump does not cycle	<ol style="list-style-type: none"> 1. Insufficient air pressure 2. Air motor jammed and/or contains loose components, i.e. Shuttle (25) installed upside down 3. Pump tube jammed and/or contains loose components 	<ol style="list-style-type: none"> 1. Increase air pressure 2. Rebuild air motor 3. Rebuild pump tube
Pump Assembly		
Pump will not prime	<ol style="list-style-type: none"> 1. Excessive cycling speed 2. Air leaking into pump tube 3. Pump leaking internally 	<ol style="list-style-type: none"> 1. Reduce air pressure 2. Tighten connection 3. See Pump SER Service Guide
Pump cycles rapidly	Product source empty	Replenish product and inspect Air Motor
Air Motor		
External Leaks		
Air leakage at top and /or bottom of Tube (1)	<ol style="list-style-type: none"> 1. Compression Nut (2) not sufficiently tight 2. Elbow (4) not sufficiently tight and/or no sealant 3. Compression Sleeve (3) not sealing properly 	<ol style="list-style-type: none"> 1. Tighten Compression Nut (2) 2. Apply thread sealant* to Elbow (4) and tighten 3. Replace Compression Sleeves (3) and Tube (1)
Air leakage at bottom of Cylinder (5)	<ol style="list-style-type: none"> 1. Worn or damaged O-Ring (18) 2. Worn or damaged Cylinder (5) 	<ol style="list-style-type: none"> 1. Replace O-Ring (18) 2. Replace Cylinder (5)
Air leakage between Adapter (16) and Body (19)	Worn or damaged O-Ring (17)	Replace O-Ring (17)
Air leakage at Toggle Cap (28 or 42)	<ol style="list-style-type: none"> 1. Initial tightening of Toggle Cap to Body (19) not sufficient 2. Damaged O-Ring (29) [Gasket(f)] 	<ol style="list-style-type: none"> 1. Tighten Toggle Cap to Body (19) 2. Replace O-Ring (29) [Gasket (f)]
Air leakage at Body Inlet (24)	<ol style="list-style-type: none"> 1. Initial tightening of Body Inlet (24) to Body (19) not sufficient 2. Worn or damaged O-Ring (23) 	<ol style="list-style-type: none"> 1. Tighten Body Inlet (24) to Body (19) 2. Replace O-Ring (23)
Product leakage at weep hole in Body (19)	Worn or damaged Seal (38)	Replace Seal (38)
Internal Leaks		
Air leakage felt at exhaust	<ol style="list-style-type: none"> 1. Worn or damaged V-Packing (13) 2. Worn or damaged Packing (8) 3. Damaged Gasket (20) 4. Worn or damaged Valve (21) 5. Worn or damaged Valve Seat (21) 6. Worn or damaged O-Ring (15) 7. Worn or damaged Cylinder (5) 8. Worn or damaged Valve Retaining Spring (26) 9. Valve Retaining Spring (26) improperly tensioned 10. Elbow (4) overtightened distorting valve seat cavity in Body (19) 	<ol style="list-style-type: none"> 1. Disassemble air motor, clean, inspect, and replace worn or damaged components. 9. Bend Valve Retaining Spring (26) in the proper direction. Measure the amount of force required to move the Valve on the Valve Seat. 10. Replace Body (19)
* Do not apply thread sealant to the first two (2) threads. Contamination can occur.		

Changes Since Last Printing

Added Compression Fitting 328306-52



Service Guide

**331378-
A1, B1,
E1, F1, H1**

High-Pressure Stripped Pump

Description

The major components of the 331378 series pumps consist of an air-operated motor and a pump tube. The air motor connects directly to the double-acting reciprocating pump tube.

These high-pressure (70:1 ratio) pumps are designed to deliver a range of light to heavy lubricants directly from their original drum.

Models 331378-A1, B1, E1, F1, and H1

Each pump model is designed with a pump tube length to accommodate different size containers. See **Figure 1**.

The difference in the length of the pump tubes for the two 12.5 kg models is due to the design of the cover.

Model 331378-E1 bolts to a cover with a flat design (Obsolete). Model 331378-F1 uses a cover with a bung adapter. See the section entitled **Accessories** for details.

Specifications

Air Motor

Piston Diameter x Stroke		Air Inlet	Max. Air Pressure	
Inches	Centimeters		psi	Bars
3 x 1-5/8	76.2 x 41.3	1/4 " NPSI (f)	100	6.9

For information on the air motor, refer to Service Guide SER 324400-5

Pump Tube

Material Outlet	Max. Material Pressure		Max. Delivery/Minute (Approximate)*		Displacement per Cycle	
	psi	Bars	Ounces	Grams	in ³	cm ³
3/8 " NPTF (f)	7000	483	29	820	0.277	4.54

* For detailed information, refer to **Figure 4**

Table 1 Model 331378 Series Specifications

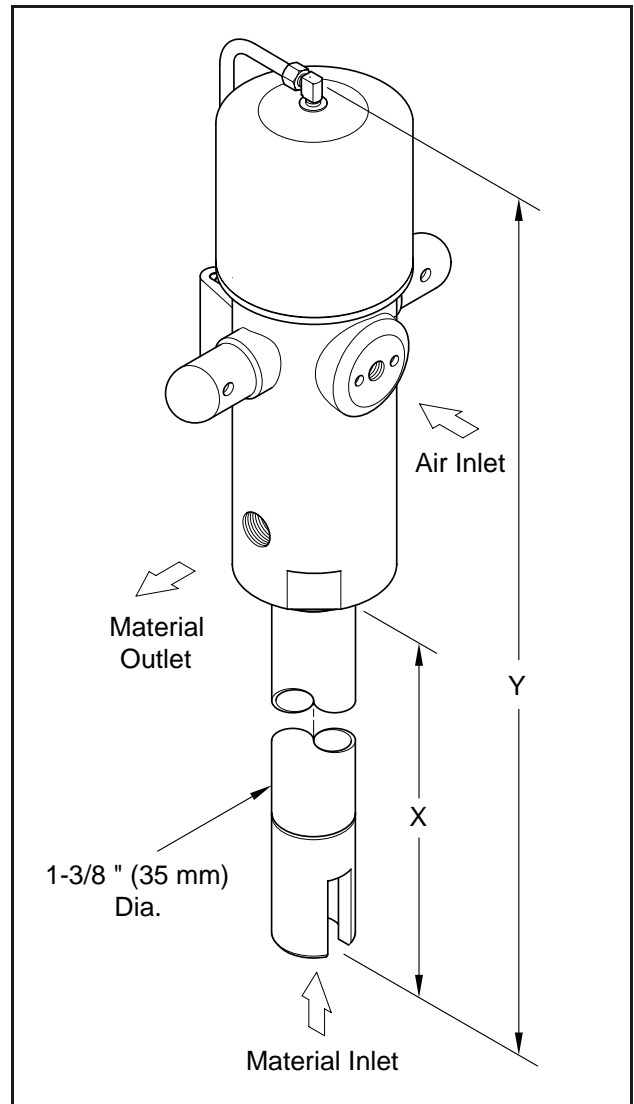

Pump Model	Container Size		X		Y	
	lbs	kg	Inches	Cm	Inches	Cm
331378-A1	120	50	27-3/4	70.5	38-1/8	96.8
331378-B1	400	180	37	94	47-3/8	120.3
331378-E1	-	12.5	12	30.5	22-3/8	56.8
331378-F1	-	12.5	15-1/4	38.7	26-5/8	67.6
331378-H1	-	20	19	48.3	29-3/8	74.6

Figure 1 High-Pressure Stripped Pump Model 331378 Series

Alemite Corporation
PO Box 473515, Charlotte, North Carolina 28247-3515

Copyright © 1998 by Alemite Corporation

This document contains confidential information that is the property of Alemite Corporation and is not to be copied, used, or disclosed to others without express written permission.

SER 331378-A1
Revision (2-98)

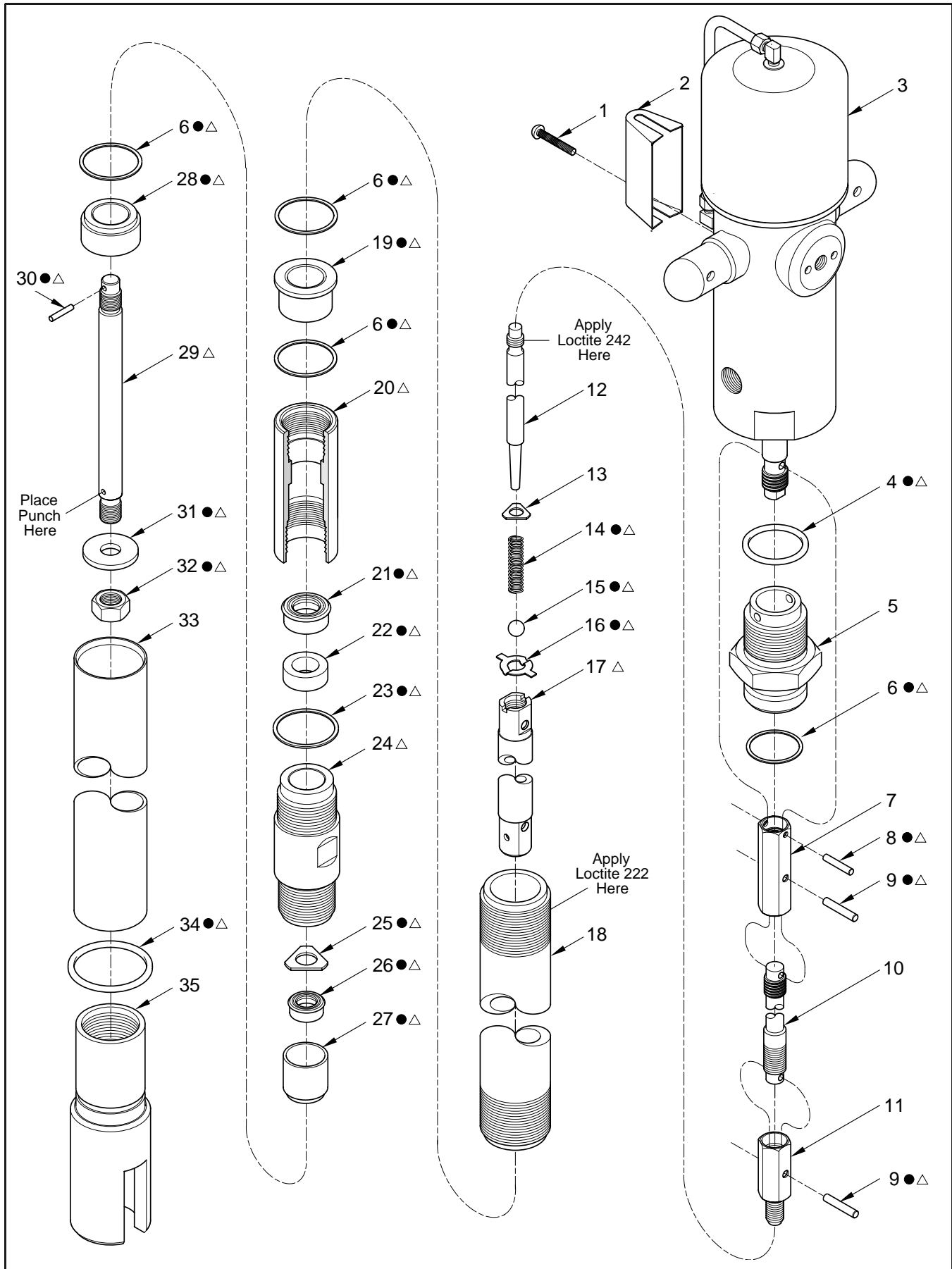

Figure 2 High-Pressure Pump Models 331378 Series - Exploded View

Item No.	Part No.	Description	Qty	Notes	Numeric Order Part # (Item #)
1	170292	Screw, Machine 8-32 x 1-1/4 " Long	1		51017 (6)
2	321085	Muffler	1		131168 (30)
3		Motor Assembly, Air	1	See SER 324400-5	170292 (1)
4	171013-12	O-Ring, 1-1/8 " ID x 1-1/4 " OD	1	● Δ	171000-20 (34)
5	324805	Adapter	1		171013-12 (4)
6	51017	Gasket (Aluminum)	4	● Δ	171700-12 (15)
7	320974	Coupling	1		172190-9 (21)
8	320971	Pin, 0.088 " Dia. x 41/64 " Long	1	● Δ	172190-10 (26)
9	320975	Pin, 0.120 " Dia. x 41/64 " Long	2	● Δ	317536 (16)
10	320704-1	Rod, 17.75 " Long	1		Model 331378-A1 317549 (25)
	320704-3	Rod, 27.06 " Long	1		Model 331378-B1 320704-1 (10)
	320704-8	Rod, 2 " Long	1		Model 331378-E1 320704-2 (10)
	320704-2	Rod, 5.5 " Long	1		Model 331378-F1 320704-3 (10)
	320704-9	Rod, 9 " Long	1		Model 331378-H1 320704-8 (10)
11	320705	Coupling	1		320704-9 (10)
12	320718	Stop, Ball	1		320705 (11)
13	321605	Washer	1		320712 (32)
14	320719	Spring, 0.75 " Long	1	● Δ	320713 (31)
15	171700-12	Ball, 3/16 " Dia.	1	● Δ	320716 (28)
16	317536	Washer, Locking	1	● Δ	320718 (12)
17	330332	Piston	1	● Δ	320719 (14)
18	337392	Tube, 21.25 " Long	1		Model 331378-A1 320971 (8)
	337392-2	Tube, 30.42 " Long	1		Model 331378-B1 320974 (7)
	337392-3	Tube, 5.5 " Long	1		Model 331378-E1 320975 (9)
	337392-1	Tube, 9 " Long	1		Model 331378-F1 321085 (2)
	337392-4	Tube, 12.5 " Long	1		Model 331378-H1 321605 (13)
19		Bearing (Brass)	1	● Δ	324400-5 (3)
20	337391	Retainer	1	Δ	324437 (35)
21		Seal, 0.540 " ID x 0.914 " OD	1	● Δ	324438-1 (33)
22		Bearing (Brass)	1	● Δ	324438-2 (33)
23		Gasket (Aluminum) 1.08 " ID	1	● Δ	324438-7 (33)
24	337388	Extension	1	Δ	324438-5 (33)
25	317549	Washer, Stop	1	● Δ	324438-8 (33)
26		Seal, 0.282 " ID x 0.532 " OD	1	● Δ	324805 (5)
27	337995	Body, Valve	1	● Δ	330329 (29)
28	320716	Seat, Valve	1	● Δ	330332 (17)
29	330329	Rod, 3.91 " Long	1	Δ	330334 (23)
30	131168	Pin, 1/16 " Dia. x 0.50 " Long	1	● Δ	337388 (24)
31	320713	Disc, Primer	1	● Δ	337389 (22)
32	320712	Nut, Elastic Stop, 12- 28	1	● Δ	337391 (20)
33	324438-1	Tube, Follower, 25-9/16 " Long	1		Model 331378-A1 337392 (18)
	324438-2	Tube, Follower, 34-11/16 " Long	1		Model 331378-B1 337392-1 (18)
	324438-7	Tube, Follower, 9-13/16 " Long	1		Model 331378-E1 337392-2 (18)
	324438-5	Tube, Follower, 13-5/16 " Long	1		Model 331378-F1 337392-3 (18)
	324438-8	Tube, Follower, 16-13/16 " Long	1		Model 331378-H1 337392-4 (18)
34	171000-20	O-Ring, 1 " ID x 1-1/4 " OD	1	● Δ	337393 (19)
35	324437	Body, Primer	1		337995 (27)

Legend:
Part numbers left blank (or in *italics*) are not available separately
● Δ designates a repair kit item

Repair Kits

Part No.	Kit Symbol	Description	Notes
393514	●	Kit, Major Repair	
393516	Δ	Kit, Conversion	See Page 4.
393530-9		Kit, Seal [includes five (5) of item number 21]	
393530-10		Kit, Seal [includes five (5) of item number 26]	

Early Model Pumps

The earlier versions of these model pumps did not contain seals in the tube assembly. The Piston and Lower Rod cycled in “select-fit” bores. See **Figure 3**.

Any earlier model pump that has not been repaired since 1983 requires a 393516 conversion kit.

Conversion Kit

NOTE: In addition to the contents within the kit, the existing pump tube must be replaced. See **Table 2** for the appropriate part number.

Install the Kit

To reassemble the pump with the conversion kit, follow the procedures outlined in the section entitled **Assembly**.

Pump Model	Pump Tube	
	Part No.	Length
331378-A1	337392	21.25 "
331378-B1	337392-2	30.42 "
331378-E1	337392-3	5.5 "
331378-F1	337392-1	9 "
331378-H1	337392-4	12.5 "

Table 2 Pump Model Comparison with Pump Tube

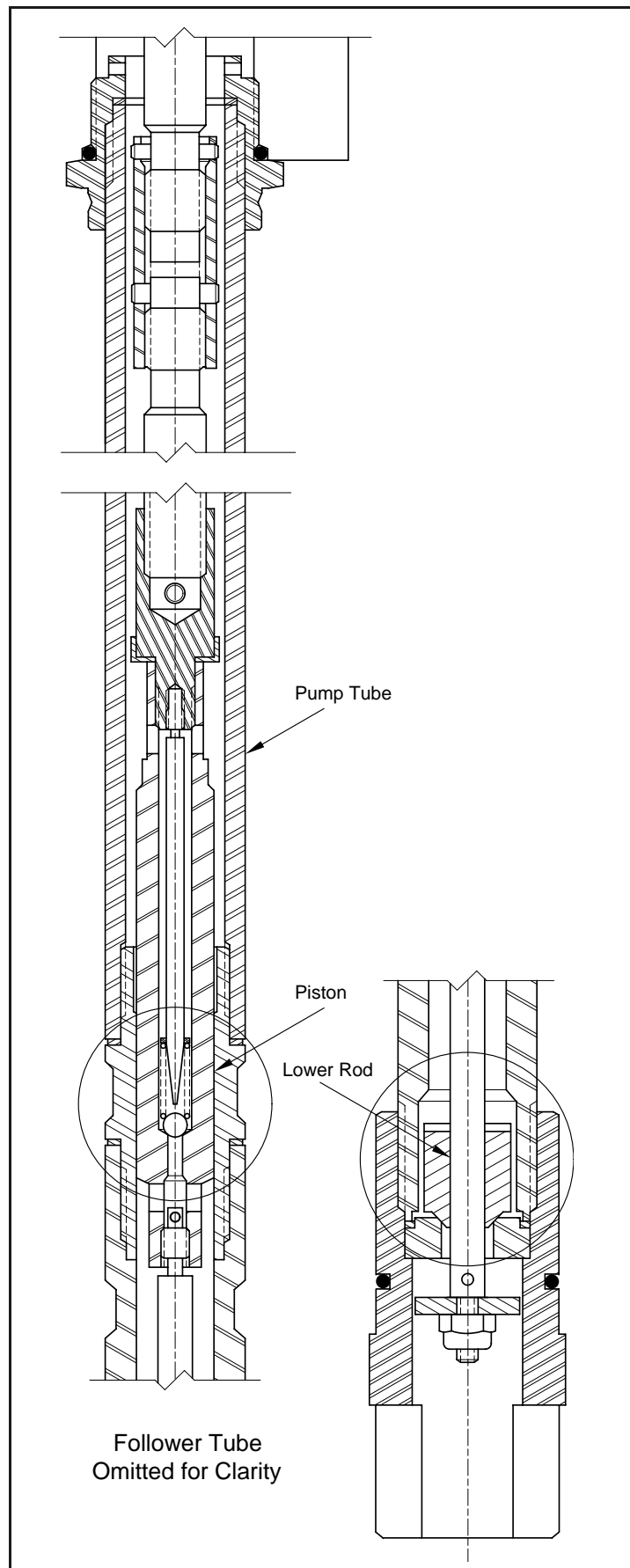

Figure 3 Early Model Pump Tubes - Section View

Accessories

Model Number	Container Size	Follower	Cover	Bung Adapter
331378-A1	120 lbs	338802	338371	326750
	50 kg	338993	338983	
331378-B1	400 lbs	338911	318040-4	
	180 kg	338994	338984	
331378-E1	12.5 kg	338991	Obsolete *	Not Applicable
331378-F1			338981	326750
331378-H1	20 kg	338992	338982	

* Design is flat for bolt-on application

Table 3 331378 Model Series Accessories

Performance Chart

A pump's ability to deliver material is based on the pressure (psi/Bars) and quantity (cfm/lpm) of air supplied to the motor and the amount of material discharge [back] pressure to be overcome within the system.

This chart contains curves based on three different air pressures. The curves relate delivery in ounces (grams) per minute (X axis) to air consumption in cubic feet (liters) per minute (right Y axis) and to material discharge pressure in psi/Bars (left Y axis).

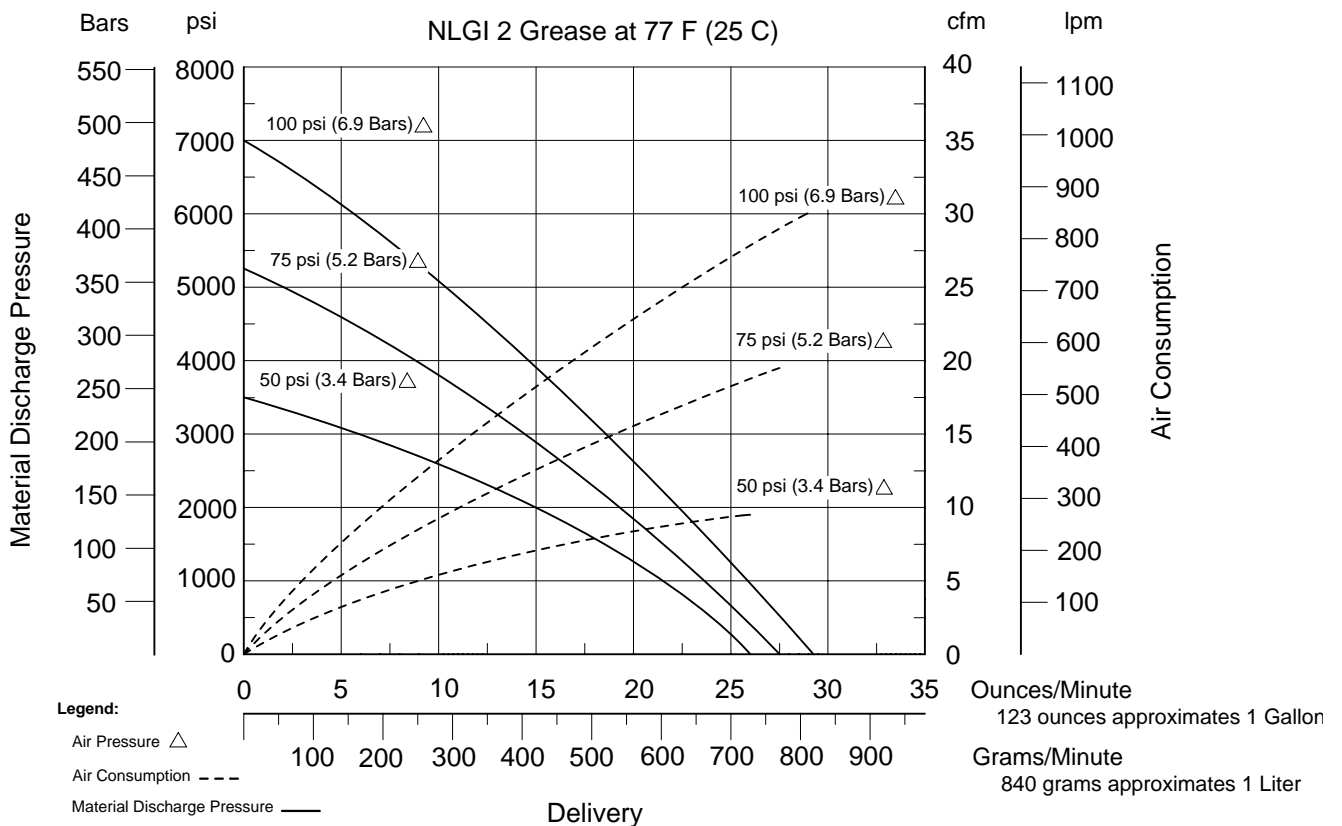

Figure 4 Delivery versus Discharge Pressure and Air Consumption

Service Hints

Refer to the Overhaul Procedures for Details

Replace Air Motor Packing Group at Pump Overhaul

Refer to Air Motor Service Guide for Details

Make Sure Adapter is Flush with Air Motor Base

Air Motor Packing Group
may Contain Improper Components

Apply Loctite 242 to Ball Stop at Initial Assembly

Ball Check may not Operate Properly

Check to Ensure Ball Seats Properly in Piston

Leakage can Occur

Check to Ensure Ball Moves a Minimum of 1/8 " (3.2 mm)

Pump may not Prime

Check to Ensure the O-Ring is Installed

Follower Plate will not Operate Correctly

Do not Overtighten the Nut

Damage to the Pin may Occur

IMPORTANT: Prior to performing any maintenance procedure, the following safety precautions must be observed. Personal injury may occur.



WARNING

Do not use halogenated hydrocarbon solvents such as methylene chloride or 1,1,1-trichloroethane in this pump. An explosion can result within an enclosed device capable of containing pressure when aluminum and/or zinc-plated parts in the pump come in contact with halogenated hydrocarbon solvents.

Release all pressure within the system prior to performing any overhaul procedure.

- **Disconnect the air supply line from the pump motor.**
- **Into an appropriate container, operate the control valve to discharge remaining pressure within the system.**

Never point a control valve at any portion of your body or another person. Accidental discharge of pressure and/or material can result in injury.

Read each step of the instructions carefully. Make sure a proper understanding is achieved before proceeding.

Overhaul

NOTE: Refer to **Figure 2** for component identification on all overhaul procedures.

Disassembly

1. Secure the pump assembly in a soft-jaw vise at Adapter (5).
2. Extend Rod (29) from Primer Body (35).
 - Apply air to the motor as necessary.
3. Gently remove Nut (32) from the Rod.
 - Use an appropriate size punch in the hole of the Rod to prevent rotation. See **Figure 2**.
4. Remove Primer Disc (31) from the Rod.
5. Push the Rod into the Primer Body.

Pump Tube (Outer Components)

6. Rotate the Primer Body.
 - Use a large wrench or other suitable tool.

NOTE: The pump tube will break at one of three places. Unscrew the separated portion from the inner components of the pump tube assembly.

7. Remove Follower Tube (33) [assembly] from the inner tube assembly.
8. Unscrew the air motor from Adapter (5).
 - Rotate the air motor assembly.
9. Remove O-Ring (4) from the Adapter.

NOTE: If the pump was not leaking at the top of Tube (18), do not separate the Adapter from the Tube. Components are locked with Loctite 222.

10. Unscrew Tube (18) from the Adapter as required.
 - Remove Gasket (6).
11. Clamp Retainer (20) horizontally in a soft-jaw vise.
12. Unscrew the Primer Body from Extension (24).
13. Remove O-Ring (34) from the Primer Body.

IMPORTANT: Remove Valve Seat (28) squarely from the Primer Body. Should the Valve Seat cock during removal, realign and start again. Gasket (6) may interfere.
14. Remove Valve Seat (28) from the Primer Body.
15. Remove Gasket (6) from the Valve Seat.
16. Unscrew the Extension from the Retainer.
17. Remove Gasket (23) from the Extension.
18. Remove Valve Body (27) from the Extension.
 - Remove Stop Washer (25).
19. Remove Seal (26) from the Valve Body.
20. Remove Bearing (22) and Seal (21) from the Retainer.
21. Unscrew Tube (18) from the Retainer.
22. Remove Gasket (6), Bearing (19), and additional Gasket (6) from the Retainer.

Pump Tube (Inner Components)

23. Remove Pin (8) that secures Coupling (7) to the air motor rod.
 - Unscrew the Coupling assembly from the air motor rod.
24. Clamp Coupling (11) in a soft-jaw vise.
25. Remove upper Pin (9) that secures Coupling (7) to Rod (10).
 - Unscrew the Rod from the Coupling.
26. Remove lower Pin (9) that secures Coupling (11) to the Rod.
 - Unscrew the Rod from the Coupling.
27. Remove Pin (30) that secures Piston (17) to Rod (29).
 - Unscrew the Rod from the Piston.
28. Straighten the tabs on Locking Washer (16).
29. Unscrew Piston (17) from the Coupling.
30. Remove the Locking Washer from the Piston.
31. Remove Ball (15) from the Piston.
32. Remove Spring (14) and Washer (13) from Ball Stop (12).

NOTE: Separate the Ball Stop from the Coupling only if the connection is loose.
33. Unscrew the Ball Stop from the Coupling as needed.

Clean and Inspect

NOTE: Use the appropriate repair kit for replacement parts. Make sure all the components are included in the kit and in good condition before discarding used parts.

1. Clean all metal parts in cleaning solvent. The solvent should be environmentally safe.
2. Inspect all parts for wear and/or damage.
 - Replace as necessary.
3. Inspect Piston (17) closely. Use a magnifying glass to detect any wire draw marks.
 - Replace as necessary.
4. Closely inspect the mating surfaces of all components for any imperfections. Ensure a smooth and clean contact is obtained when assembled.

EXAMPLE: Place Ball (15) into Piston (17). Fill the Piston with solvent. Make sure no leakage occurs.

Assembly

NOTE: Prior to assembly, certain components require lubrication in clean oil. Refer to **Table 4** for details.

Pump Tube (Inner Components)

NOTE: Refer to **Figure 5** for a section view of the pump tube assembly.

1. Place Ball (15) into Piston (17).

NOTE: If the Ball Stop was previously locked with Loctite 242, skip procedure 2.

2. Screw and seat Ball Stop (12) [with Loctite 242] into Coupling (11) as needed.
 - Follow the thread sealant manufacturer's recommendations.
 - Tighten securely.
3. Install Washer (13) and Spring (14) onto the Ball Stop.
4. Position Locking Washer (16) into the groove on the Piston.
5. Screw the Coupling assembly into the Piston.
 - Tighten from 19 to 21 foot pounds (25.4 - 28.3 Nm).
 - Continue to tighten and align the nearest flat of the Coupling with the tabs on the Locking Washer as necessary.

***IMPORTANT:** Press on the Ball to ensure it moves a minimum of 1/8 " (3.2 mm) prior to contact with the Ball Stop. Should the value be less, check to ensure the Ball Stop is fully seated in the Coupling.*

6. Bend the tabs of the Locking Washer upward onto the Coupling.
7. Screw Rod (29) into the Piston until the pin holes align.

NOTE: Use a spot of grease on all pins to prevent movement.

8. Install Pin (30).

Item No. on Figure 2	Description
4	O-Ring, 1-1/8 " ID x 1-1/4 " OD
21	Seal, 0.540 " ID x 0.914 " OD
26	Seal, 0.282 " ID x 0.532 " OD
34	O-Ring, 1 " ID x 1-1/4 " OD

Table 4 Lubricated Components

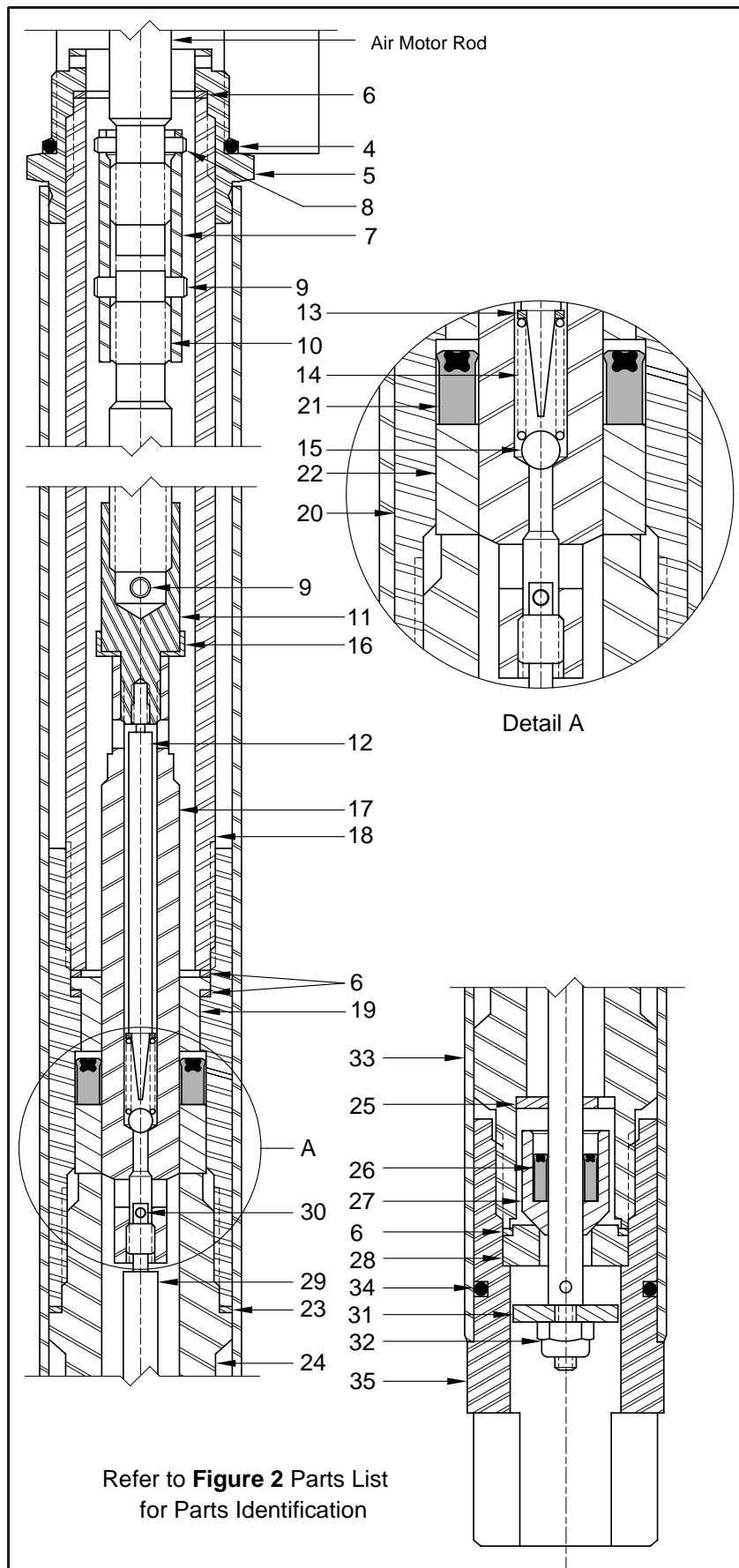

Refer to **Figure 2** Parts List
for Parts Identification

9. Screw Rod (10) into Coupling (11) until the pin holes align.
 - Install Pin (9).
10. Screw Coupling (7) [center hole first] onto the Rod until the pin holes align.
 - Install additional Pin (9).
11. Secure the air motor assembly in a soft-jaw vise.
12. Screw the Coupling assembly onto the air motor rod until the pin holes align.
 - Install Pin (8).

Pump Tube (Outer Components)

13. Install and seat Seal (21) [lips first] into the bottom of Retainer (20). See **Figure 2**.
14. Install and seat Bearing (22) into the bottom of the Retainer.
15. Install Gasket (23) onto the top of Extension (24).
16. Screw the Extension (Gasket end first) into the bottom of the Retainer.
 - Do not tighten at this time.
17. Install Gasket (6) into the top of the Retainer.
18. Install and seat Bearing (19) [small diameter first] and additional Gasket (6) into the top of the Retainer.

19. Screw Tube (18) into the top of the Retainer.
 - Do not tighten at this time.
20. Install and seat Gasket (6) into Adapter (5).

IMPORTANT: If a primer is used with Loctite 222, the curing time is greatly reduced.

21. Screw the Tube assembly [with Loctite 222] into the Adapter.
 - Follow the thread sealant manufacturer's recommendations.
 - Do not tighten at this time.
22. Install O-Ring (4) onto the Adapter.

Figure 5 Pump Tubes 337384-A1, B1, C1, F1, and G1 - Section View

23. Apply grease to Piston (17).
- This will aid the installation process.

CAUTION

Install the outer component assembly onto the inner assembly with care. Damage to Seal (21) can occur.

24. Install the outer component assembly onto the inner assembly.
- Use a slight twisting motion to pass the Seal.
 - At the same time thread the Adapter into the base of the air motor.

IMPORTANT: Make sure the flange portion of the Adapter seats flush against the base of the air motor. Should a gap exist, inspect the components of the air motor packing group.

25. Install Stop Washer (25) into the Extension.
26. Install and seat Seal (26) [heel end first] into Valve Body (27).

27. Install the Valve Body assembly (Seal first) onto Rod (29).
- Make sure the Valve Body assembly seats properly in the Extension.
28. Install Follower Tube (33) over the outer tube assembly.
29. Install O-Ring (34) onto Primer Body (35).
30. Install and seat Valve Seat (28) [large diameter first] into the Primer Body.
31. Install and seat Gasket (6) into the Primer Body.
32. Screw the Primer Body onto the Extension.
33. Place a large wrench or other suitable tool into the slot of the Primer Body.
- Tighten all the components of the assembly securely.
 - Crush all Gaskets.
34. Extend Rod (29) from the Primer Body.
- Apply air to the motor as necessary.
35. Install Primer Disc (31) onto the Rod.
36. Gently screw Nut (32) onto the Rod.
- Use an appropriate size punch in the hole of the Rod to prevent rotation. See **Figure 2**.
 - Do not overtighten.

Bench Test

1. Make sure air pressure at the regulator reads zero.
2. Install air Connector (4) to the inlet of the air motor.
3. Connect Air Coupler (5) to the Connector.
4. Slowly supply air pressure [not to exceed 20 psi (1.4 Bars)] to the pump's motor.
 - The pump assembly should cycle.

If the pump assembly does not cycle, refer to the **Troubleshooting Chart** for details.

With air pressure at zero:

5. Connect a product hose to the pump's material outlet.
 - Direct the hose into an appropriate collection container.
6. Place the pump in grease.
7. Slowly supply air pressure to the pump's motor.
8. Allow the pump to cycle slowly until the system and grease is free of air.

If the pump assembly does not prime, refer to the **Troubleshooting Chart** for details.



WARNING

Should leakage occur anywhere within the system, disconnect air to the motor. Personal injury can occur.

With air pressure at zero:

9. Attach a control valve to the outlet hose of the pump.
10. Set the air pressure to 100 psi (6.9 Bar).
11. Operate the control valve into a container.
12. Allow the pump to cycle until the system and grease is once again free of air.
13. Shut off the control valve.
 - Visually inspect the pump for external leaks.
 - The pump should not cycle.

If the pump does not stall, refer to the **Troubleshooting Chart** for details.

14. Check the motor for air leakage.

If the motor leaks, refer to the **Air Motor Service Guide** for details.

Installation

Additional items that should be incorporated into the air piping system are illustrated in **Table 5**.

Part Number	Description
338860	Moisture Separator/Regulator & Gauge Combination
5604-2	Moisture Separator
7604-B	Regulator and Gauge
5904-2	Lubricator *

Table 5 *Air Line Components*

* Although the air motor is lubricated at the factory, the life of the motor can be extended with the use of a lubricator.

Troubleshooting Chart

Pump Indications	Possible Problems	Solution
Pump does not cycle	<ol style="list-style-type: none"> 1. Air motor not operating properly 2. Pump tube jammed and/or contains loose components 3. Insufficient air pressure 	<ol style="list-style-type: none"> 1. Inspect air motor and rebuild or replace as necessary 2. Rebuild pump tube 3. Increase air pressure
Pump will not prime	<ol style="list-style-type: none"> 1. Excessive cycling speed 2. Pump leaking internally 	<ol style="list-style-type: none"> 1. Reduce air pressure 2. See Internal Leaks
Pump cycles rapidly	Product source empty	Replenish product
Pump cycles continuously, or slowly (once or twice/hour)	<ol style="list-style-type: none"> 1. Pump leaking internally 2. Pump leaking externally 3. Distribution system leaking 	<ol style="list-style-type: none"> 1. See Internal Leaks 2. See External Leaks 3. Correct leak
External Leaks		
Product leakage visible at top of Adapter (5)	<ol style="list-style-type: none"> 1. Initial tightening of Adapter (5) to Air Motor Assembly (3) not sufficient 2. Damaged O-Ring (4) 	<ol style="list-style-type: none"> 1. Tighten Adapter (5) into Air Motor Assembly (19) 2. Replace O-Ring (4)
Product leakage visible at top of Follower Tube (33)	<ol style="list-style-type: none"> 1. Initial tightening of Tube (18) to Adapter (5) not sufficient 2. Initial tightening of Tube (18) to Retainer (20) not sufficient 3. Initial tightening of Extension (24) to Retainer (20) not sufficient 4. Initial tightening of Extension (24) to Primer Body (35) not sufficient 5. Gasket(s) (6) worn or improperly crushed 6. Gasket (23) worn or improperly crushed 	<ol style="list-style-type: none"> 1. Tighten Tube (18) into Adapter (5) 2. Tighten Tube (18) into Retainer (20) 3. Tighten Extension (24) into Retainer (20) 4. Tighten Extension (24) into Primer Body (35) 5. Replace Gasket(s) (6) 6. Replace Gasket (23)
Product leakage visible at bottom of Follower Tube (33)	Damaged O-Ring (34)	Replace O-Ring (34)
Internal Leaks		
Pump does not prime or cycles continuously, or slowly (once or twice/hour)	<ol style="list-style-type: none"> 1. Foreign material between Ball (15) and seat in Piston (17) 2. Foreign material between Valve Body (27) and Valve Seat (28) 3. Worn or damaged Ball (15) 4. Worn or damaged Piston (17) 5. Worn or damaged Spring (14) 7. Worn or damaged Valve Body (27) 8. Worn or damaged Valve Seat (28) 9. Worn or damaged Seal (21) 10. Worn or damaged Seal (26) 11. Worn or damaged Rod (29) 	<ol style="list-style-type: none"> 1. Locate and eliminate source of foreign material. 2. Disassemble pump tube, clean, inspect, and replace worn or damaged components.

Changes Since Last Printing

Added Models 331378-E1, F1, and H1



**SERVICE INSTRUCTIONS
MODEL 6438
VOLUME CONTROL VALVE**

6438

DESCRIPTION

This medium pressure, high volume control valve is designed for lubricating track roll bearings. Since this model does not attach directly to the fitting, a whip-end hose assembly is required.

NOTE: *The hose assembly must be PURCHASED SEPARATELY. Consult your local Alemite representative or Sales Catalogue for information on current hose assemblies.*

SPECIFICATIONS

Inlet 3/8" NPTF (f)

Outlet 1/4" NPTF (f)

OPERATION

1. Thread hose assembly to lubricant outlet.
2. Attach material line to lubricant inlet.
3. Operate lever to start lubricant flow.

GENERAL SAFETY REQUIREMENTS

Because these units are incorporated into high pressure pumping systems, the following safety precautions **MUST** be observed at all times:

1. Do not exceed the pressure rating of any component in the system.
2. Protect material lines and air lines from damage or puncture.
3. Check all hoses for weak or worn condition prior to daily operations, making certain that all connections and fittings are secure.
4. Never point the dispensing device at oneself or any other person. Accidental discharge of pressure and material may result in serious injury.

NOTE: *Do not relieve pressure by discharging into hand.*

5. Release all pressures within the system before attempting to service or remove any part of the control valve.
6. Read all Instruction Sheets carefully and thoroughly before attempting to assemble, disassemble or operate the system. Observe any additional safety requirements not listed in this sheet but included in other instructional materials.

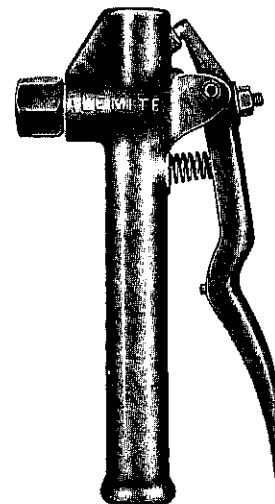

Model 6438

**Volume
Control
Valve**

MAINTENANCE

If lubricant leaks at plunger 47130, replace needle leather 41911:

1. Loosen nut 77676 and remove adjustment screw 47122.
2. Displace pin 47126 and remove lever 47133.
3. Remove check valve assembly 302391.
4. Using a thin metal rod, push plunger assembly 302390 out through check valve opening.
5. Unthread plunger 47130 from stem 47127 and remove needle leather.
6. Replace and reassemble by reversing Steps 1 through 5.

If lubricant flow is restricted:

1. Loosen nut 77676.
2. Position adjustment screw 47122 so it rests lightly against plunger 47130.
3. Secure by tightening nut.

If lubricant leaks when control valve is closed, replace ball 171700-16:

1. Remove spring retainer 47129, spring 47135 and ball 171700-16.
2. Clean adapter 337342 and replace ball 171700-16.
3. Reassemble.

FOR FURTHER SERVICE, CONTACT YOUR LOCAL ALEMITE DISTRIBUTION CENTER



**ALEMITE CORPORATION
167 ROWELAND DR. JOHNSON CITY, TN 37601**



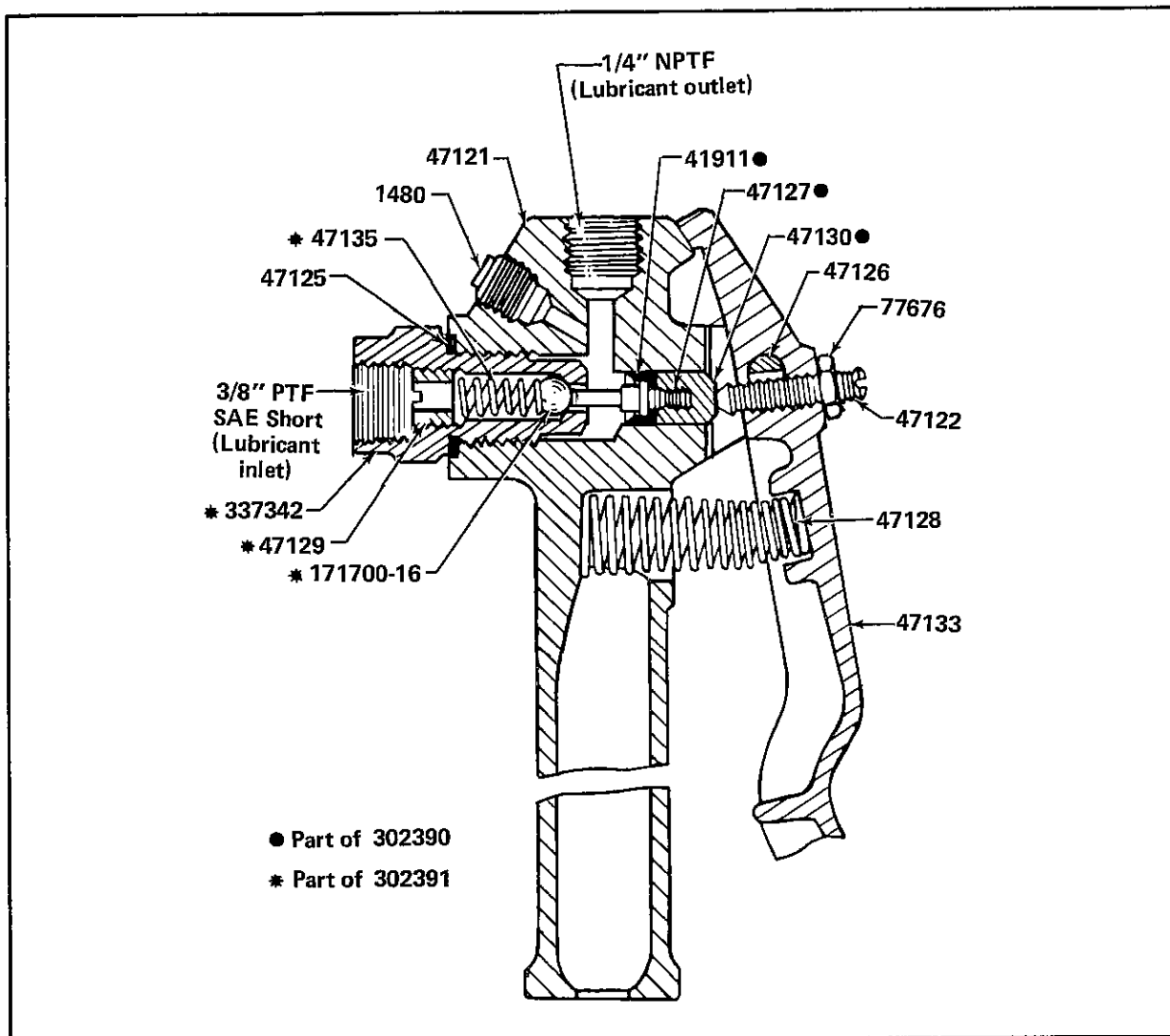

PARTS LIST

PART NO.	DESCRIPTION	PART NO.	DESCRIPTION
1480	Sq. Head Pipe Plug, 1/8"	47130	Plunger
41911	Needle Leather	47133	Lever
47121	Valve Body	47135	Spring, 5/16" long
47122	Adjustment Screw	171700-16	Ball
47125	Gasket, 13/16" O. D.	337342	Adapter
47126	Pin, 1-3/8" long	77676	Hex Nut, 1/4"-28
47127	Plunger Stem	302390	Plunger Assembly
47128	Spring, 2-3/4" long	302391	Check Valve Assembly
47129	Spring Retainer	—	—

NOTE: All parts listed in this instruction sheet are for reference identification in instructions and illustrations. They will not necessarily be available unless listed in current parts price list or used on current model. Purchase bolts, nuts and other standard items from local hardware supplier. Refer to current parts price lists and bulletins for availability before ordering parts. ALWAYS mention part number, quantity, description and model used on.

PART CHANGES SINCE LAST PRINTING

171700-16 was 47313, 337342 was 51894

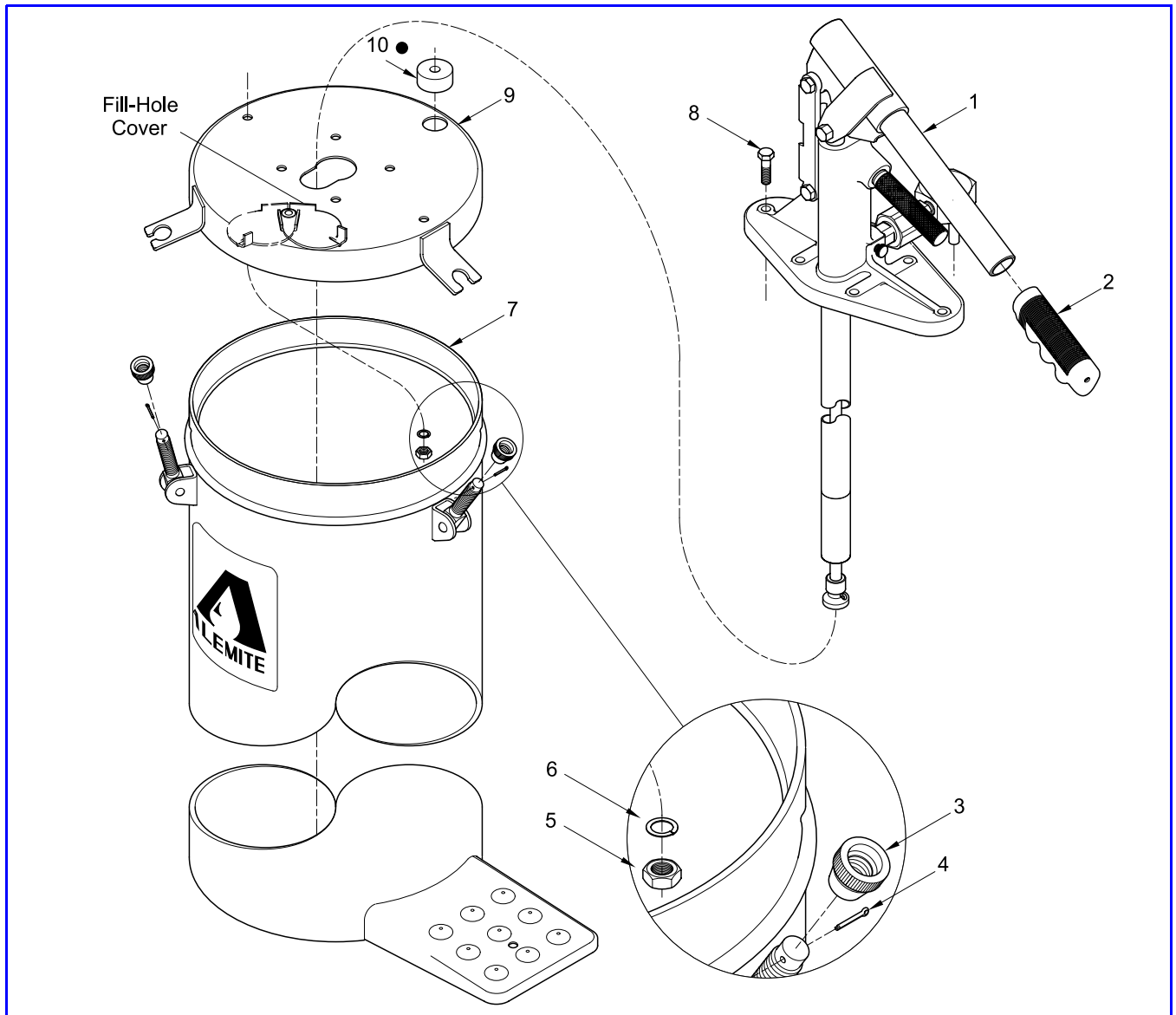

Item No.	Part No.	Description	Qty	Notes	Numeric Order Part # (Item #)
1	310750-4	Pump Assembly	1	See Figure 2-B	12369 (6)
2		Grip, Handle	1		77650 (5)
3	303087	Knob	3		77736 (8)
4		Pin, Cotter	3		172212-1 (4)
5		Nut	6		303087 (3)
6		Washer, Lock	6		308725-B4 (7)
7	308725-B4	Container Assembly (w/o Decal)	1		308726-B4 (9)
8		Screw	6		310750-4 (1)
9	308726-B4	Cover Assembly	1		337066 (2)
10		Seal	1	●	337438 (10)

Legend:

Part numbers left blank (or in *italics*) are not available separately

● designates a repair kit item - See **Figure 2-B** for part number

Figure 2-A High-Pressure Bucket Pump Model 6713-4 - Exploded View

"Porta-Kart" Dolly**DESCRIPTION**

The 6777-5 "Porta-Kart" Dolly provides a convenient method for moving bucket-type pumps with a minimum of effort.

The "Porta-Kart" comes with the necessary mounting hardware for attaching any of the Series 7149 or 7181 bucket pumps.

When any of these pumps is securely attached to the bottom plate of the "Porta-Kart," the pump can also be easily operated after it has been transported.

INSTALLATION
(FIGURE 3)

To install the 7149 or 7181 bucket pump on the "Porta-Kart," follow these steps:

1. Position the bucket pump on the plate of the cart so that the foot rest is on the tapered end of the plate.

2a. Series 7149:

Insert screw 170353 through the hole in the foot rest and the plate. Secure with lockwasher 172207-1 and hex nut 77650.

2b. Series 7181:

Insert screw 170361 through the hole in the foot rest and the plate. Secure with elastic stop nut 170989.

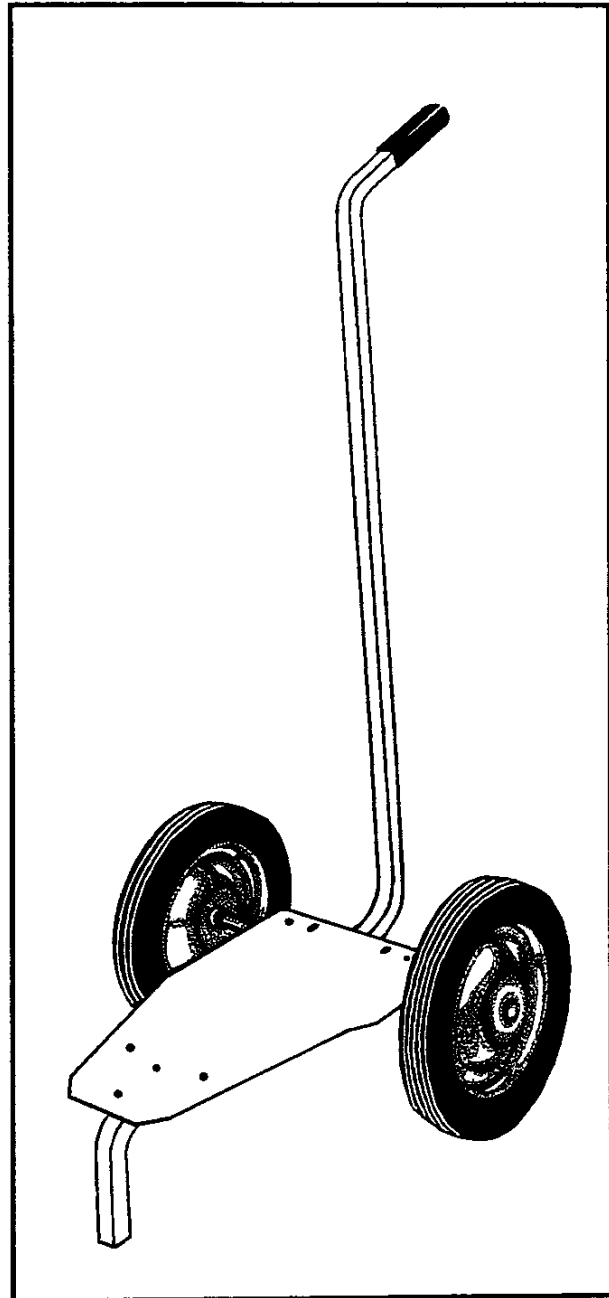

Figure 1: Model 6777-5 "Porta-Kart" Dolly

FOR FURTHER SERVICE, CONTACT YOUR LOCAL ALEMITE DISTRIBUTION CENTER



ALEMITE CORPORATION
4701 PARK RD CHARLOTTE NC 28209-9967

3. Place the two clamps 322892 on the rim of the bucket pump and secure to the plate of the cart with two screws 170349, two lockwashers 172207-1 and two hex nuts 77650 (Figure 3a).

4. Series 7149 only:

Attach the elbow-extension 327333 into the lubricant outlet of the pump.

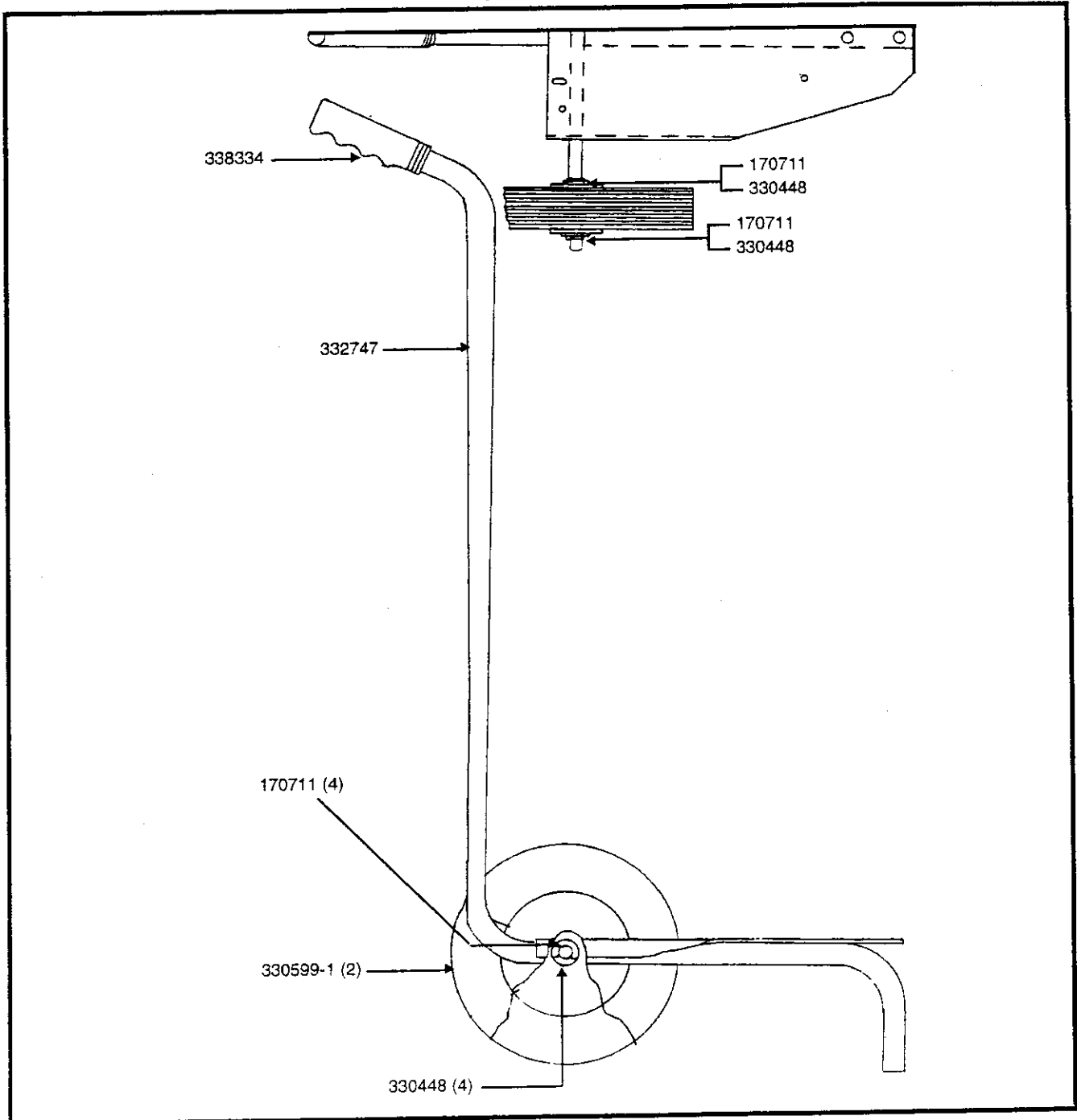

Figure 2: Components of "Porta-Kart" Dolly

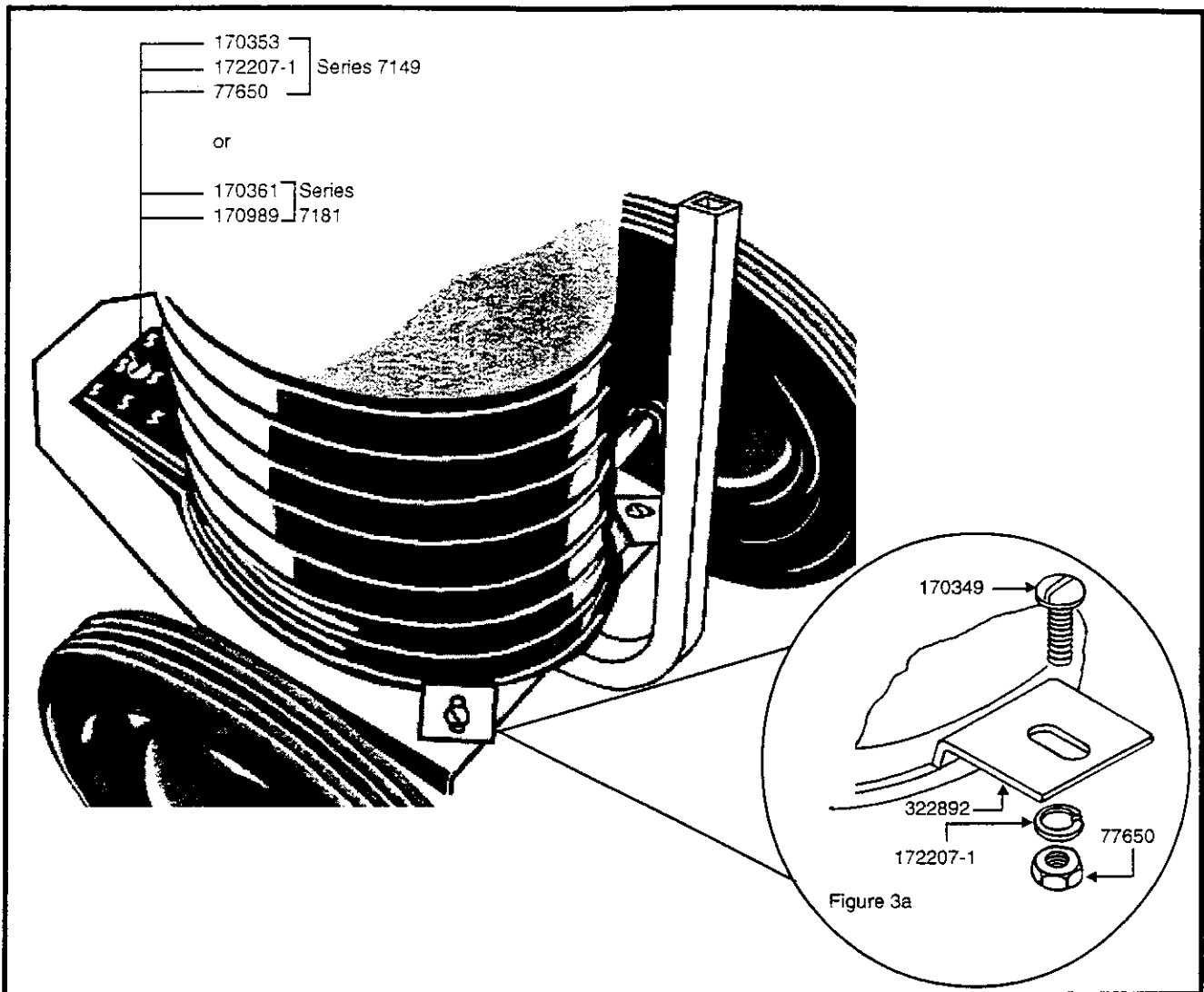

Figure 3: Attaching Bucket Pumps or Grease Pails

PARTS LIST - Model 6777-5 "Porta-Kart" Dolly

Part No.	Description	Qty.
77650	Hex-Head Nut, 1/4-20	3
+ 170349	Pan-Head Screw, 1/4-20 x 3/4" long	2
+ 170353	Pan-Head Screw, 1/4-20 x 1" long	1
+ 170361	Round-Head Screw, 1/4-20 x 2" long	1
170711	"E" Retaining Ring	4
+ 170989	Elastic Stop Nut, 1/4-20	1
+ 172207-1	Helical Spring Lockwasher, 1/4" I.D.	3
322892	Clamp	2
+ 327333	Elbow-Extension, 3/8" NPTF	1
330448	Washer, 21/32" I.D. x 1" O.D.	4
330599-1	Wheel, 10" Diameter	2
+ 332747	Frame Assembly	1
+ 338334	Handle Grip, Plastic	1

+ Not available as a separate purchased part.

NOTE: The parts listed in this instruction sheet are for reference identification in the instructions and illustrations. Some of them are not available as separate parts and these are noted in the parts list. Standard items such as nuts, bolts, etc. should be purchased at a hardware store. Refer to the current parts price list and bulletins before ordering parts, and always give a part number, quantity, description and model where used when ordering parts. Parts availability and prices are subject to change without notice.

CHANGES SINCE LAST PRINTING

Deleted assembly procedure.

ADDITIONAL PARTS LISTING

FOLLOWER PLATE ASSEMBLY WITH SPRING

<u>PART NUMBER</u>	<u>DESCRIPTION</u>
FP-5-70	Follower Plate for 5-70 & Grommet
SPRG 4X13	Large Spring for 5-70
SPRG 2X11.5	Small Spring for 5-70
SNAP RING	Snap Ring
1.25 WASHER	1 1/4" Washer for Follower Plate
SCL-25-SS (2)	Spring Retaining Clip
327137	Handle

HOSE ASSEMBLY – Order complete – Part # 10-8540

<u>PART NUMBER</u>	<u>DESCRIPTION</u>
51541	1/2" Straight Swivel
51543	1/2" Z Swivel
3/8X1/2 CPLG	3/8"X1/2" Female Coupling
38-120-38M-38M	1/2"- 10 Foot Hose
6438	Control Handle w/ Bleeder Assembly
47123	Needle for 6438 Bleed Assembly
47124	Body for 6438 Bleed Assembly
301296	Adapter
.25 TEE	1/4" Tee
15MGF	15,000 PSI Gauge
GC-250	Gauge Guard
16	Straight Swivel
20	Hose
43379	Adapter
6	Giant Buttonhead Coupler

OPTIONAL EQUIPMENT

<u>PART NUMBER</u>	<u>DESCRIPTION</u>
7604-B*	Air Line Regulator with Gauge
5604-2*	Moisture Separator
5904-2*	Airline Lubricator

***Adapters required depending upon your configuration.**